



carlo moretti









carlo moretti





Carlo Moretti è una eccellenza italiana, una storia di coraggio, tenacia e innovazione, ma soprattutto un'impresa visionaria che con sapienza e lungimiranza ha saputo infondere grandi emozioni permeando l'intima dimensione dell'abitare. Figli di imprenditori del vetro, Carlo e Giovanni Moretti hanno intrapreso nel 1958, appena ventenni, la loro avventura, distinguendosi per la particolare capacità di unire alla secolare tradizione dei maestri vetrai una sensibilità attenta alla cultura progettuale e artistica contemporanea.

Carlo Moretti is not only an example of Italian excellence, a story of courage, perseverance and innovation, but above all, of a visionary undertaking that had the skill and long-sightedness to inspire great sensations that would permeate the intimate domestic sphere. The sons of a glass entrepreneur, Carlo and Giovanni Moretti began their adventure in 1958 when they were just twenty; they made their mark with their particular skill at combining the centuries-old tradition of glass-makers with sensitivity towards contemporary artistic culture and design.





Carlo Moretti con la riedizione delle lampade storiche offre il tesoro nascosto di una “fabbrica d’autore” dove creatività e impresa convergono in una firma autorevole. La produzione basa la sua singolarità sulla specializzazione di un gruppo di maestri che, come una grande orchestra, interpreta il progetto della luce traducendolo nelle forme del Cristallo di Murano, soffiato a bocca, rifinito a mano, firmato e datato. Gli oggetti traggono così origine dall’incontro tra il pensiero disegnato e la sapiente manualità dei maestri, abili nel plasmare una materia viva e imprevedibile.

*With the revival of its historical lamps, Carlo Moretti is offering the hidden treasure of a ‘factory of originals’ in which creativity and enterprise converge in a well-established brand. The unique nature of the production is due to the specialisation of a group of glass masters who, as if they were a great orchestra, interpret the project of light, transforming it into the shapes of Murano Crystal, blown by mouth, hand finished, signed and dated. The objects are thus the result of a carefully conceived design and the expert manual skill of the glass masters who know how to shape a material that is intense and unpredictable.*



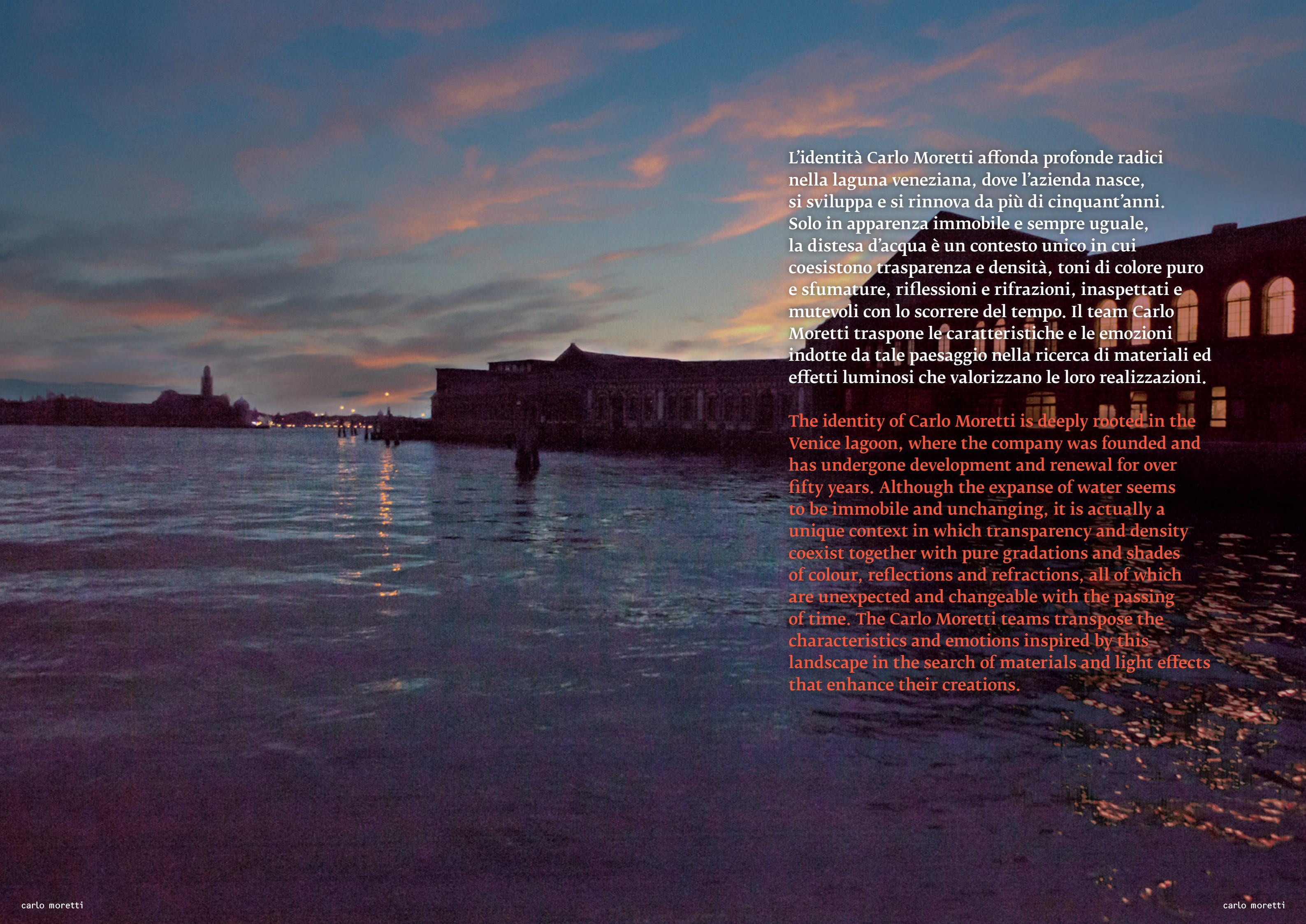

L'identità Carlo Moretti affonda profonde radici nella laguna veneziana, dove l'azienda nasce, si sviluppa e si rinnova da più di cinquant'anni. Solo in apparenza immobile e sempre uguale, la distesa d'acqua è un contesto unico in cui coesistono trasparenza e densità, toni di colore puro e sfumature, riflessioni e rifrazioni, inaspettati e mutevoli con lo scorrere del tempo. Il team Carlo Moretti traspone le caratteristiche e le emozioni indotte da tale paesaggio nella ricerca di materiali ed effetti luminosi che valorizzano le loro realizzazioni.

The identity of Carlo Moretti is deeply rooted in the Venice lagoon, where the company was founded and has undergone development and renewal for over fifty years. Although the expanse of water seems to be immobile and unchanging, it is actually a unique context in which transparency and density coexist together with pure gradations and shades of colour, reflections and refractions, all of which are unexpected and changeable with the passing of time. The Carlo Moretti teams transpose the characteristics and emotions inspired by this landscape in the search of materials and light effects that enhance their creations.



A close-up photograph of a glowing, orange-red glass object, likely a lamp component, being worked on in a furnace. The glass is held in a wooden tool and is positioned over a metal grate. The background is dark and out of focus, emphasizing the bright, molten glass.

I prodotti Carlo Moretti coniugano la tradizione e la cultura dei maestri del vetro muranesi con la passione e l'esperienza dei tecnici specializzati. Sperimentazioni e realizzazioni di apparecchi illuminanti, consolidate nel tempo, sono ora ripercorse nelle nuove collezioni che, mediante soluzioni tecnologiche avanzate, soddisfano le attuali normative conferendo maggiore efficienza anche ai prodotti storici. Un dialogo fra passato e futuro che segna in modo inconfondibile e riconoscibile l'identità Carlo Moretti.

Carlo Moretti products combine the tradition and culture of Murano glass masters with the passion and experience of specialised techniques. Experimentation and the creation of lighting equipment, consolidated over the years, have now been revived in the new collections that, using advanced technological solutions, meet current regulations and guarantee greater efficiency in the historical products as well. They are a dialogue between past and future that is the unmistakable and manifest identity of Carlo Moretti.





Il sapiente controllo di forme e comportamenti di materiali – generati da un’instabile natura e trasfigurati nelle loro consistenze, spessori ed effetti cromatici – coniugato con le molteplici fonti di ispirazione, che affondano nella conoscenza di millenarie culture, diventa nelle creazioni luminose Carlo Moretti un patrimonio di prototipi, di esemplari unici sospesi tra aria e luce. Un gioco originale di travestimenti e nascondimenti capace di celare il nuovo dentro frammenti di passato.

Carlo Moretti's luminous creations are a patrimony of prototypes with unique examples that are suspended between light and air: generated by their unstable nature and transfigured in their consistency, thickness and chromatic effects, the skilful control of the forms and behaviour of the materials is combined with infinite sources of inspiration that draw on the knowledge of millennial cultures. An original interplay of disguises and concealments that are once again able to hide fragments of the past.





Da sempre attento alla dimensione internazionale, Carlo Moretti è un marchio rivolto al futuro, dove storia, affidabilità e trasparenza vanno di concerto con l'interpretazione delle esigenze dei contesti e dei mercati contemporanei. Grazie al lavoro e alla professionalità di molte persone, l'azienda offre soluzioni customizzate ed esclusive per soddisfare i clienti più esigenti, assicurando la qualità di prodotti e processi di produzione, frutto di scelte consapevoli nei confronti della tutela dell'ambiente e della responsabilità sociale che lo rendono un modello per tutte le imprese insediate nel fragile territorio lagunare.

Having always paid particular attention to the international field, Carlo Moretti is a brand that looks towards the future, where reliability and transparency go hand in hand with understanding the needs of both the contexts and contemporary markets. Thanks to the work and professionalism of countless people, the company offers tailor-made, exclusive solutions that will satisfy the most demanding clients; at the same time they guarantee the product quality and production process, the result of specific decisions as regards environmental protection and social responsibility, making it a model for all the companies situated in the fragile territory of the Lagoon.







# carlo moretti

19	mito
41	dune
59	isole
73	maree
79	lumina
89	contract project
107	custom projects
113	inventario tecnico
126	appendici





mito







efra/2

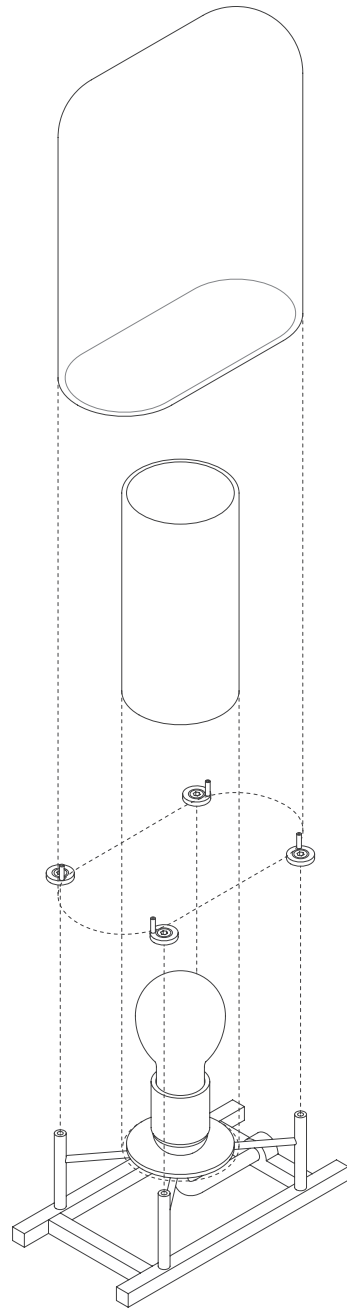

## efra

Nata dall'incontro fra le sensibilità straordinarie di due maestri, interpreta il confronto fra due volumi primari, retti da un struttura elementare in metallo. Una composizione delicata e sincera fra il cilindro che nasconde la fonte luminosa e la bolla trasparente che ne diffonde la luce.

*The fruit of an encounter between two masters with extraordinary sensitivity: it interprets the comparison of two primary volumes, supported by an elementary structure in metal. A delicate, pure composition of the cylinder concealing the the light source and the transparent bubble that diffuses the light.*

Lampada da tavolo con corpo illuminante in Cristallo di Murano, struttura metallica in ferro verniciato antracite e ottone naturale.

*Table-lamp with Murano Crystal illuminating body, metal structure in anthracite-painted iron and natural brass.*

Carlo Moretti  
con intervento di Paolo Martinuzzi  
1984

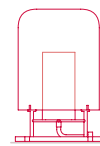

lampada da tavolo  
h. 290 mm  
Ø 200 mm  
table lamp  
h. 11.42"  
Ø 7.87"

mito











quati

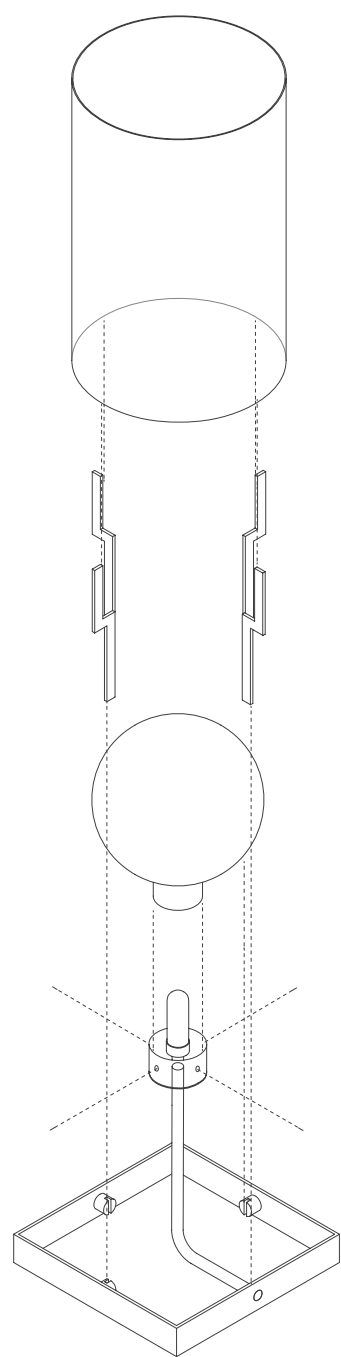

Il dialogo tra i due maestri genera l'incontro fra le geometrie di un cilindro trasparente e una perfetta sfera lattea al suo interno che, sostenute da una struttura elementare in metallo, fissano un istante luminoso senza tempo.

*The dialogue between two masters generates an encounter between the geometry of a transparent cylinder and a perfect milky sphere inside that, supported by an elementary metal structure, creates a timeless moment of light.*

Lampada da tavolo con corpo illuminante in Cristallo di Murano, struttura metallica in ferro verniciato antracite e ottone naturale.

*Table-lamp with Murano Crystal illuminating body, metal structure in anthracite-painted iron and natural brass.*

Carlo Moretti  
con intervento di Paolo Martinuzzi  
1984

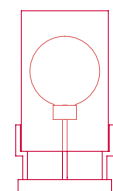

lampada da tavolo  
h. 400 mm  
Ø 190 mm  
table lamp  
h. 15.75"  
Ø 7.48"

mito





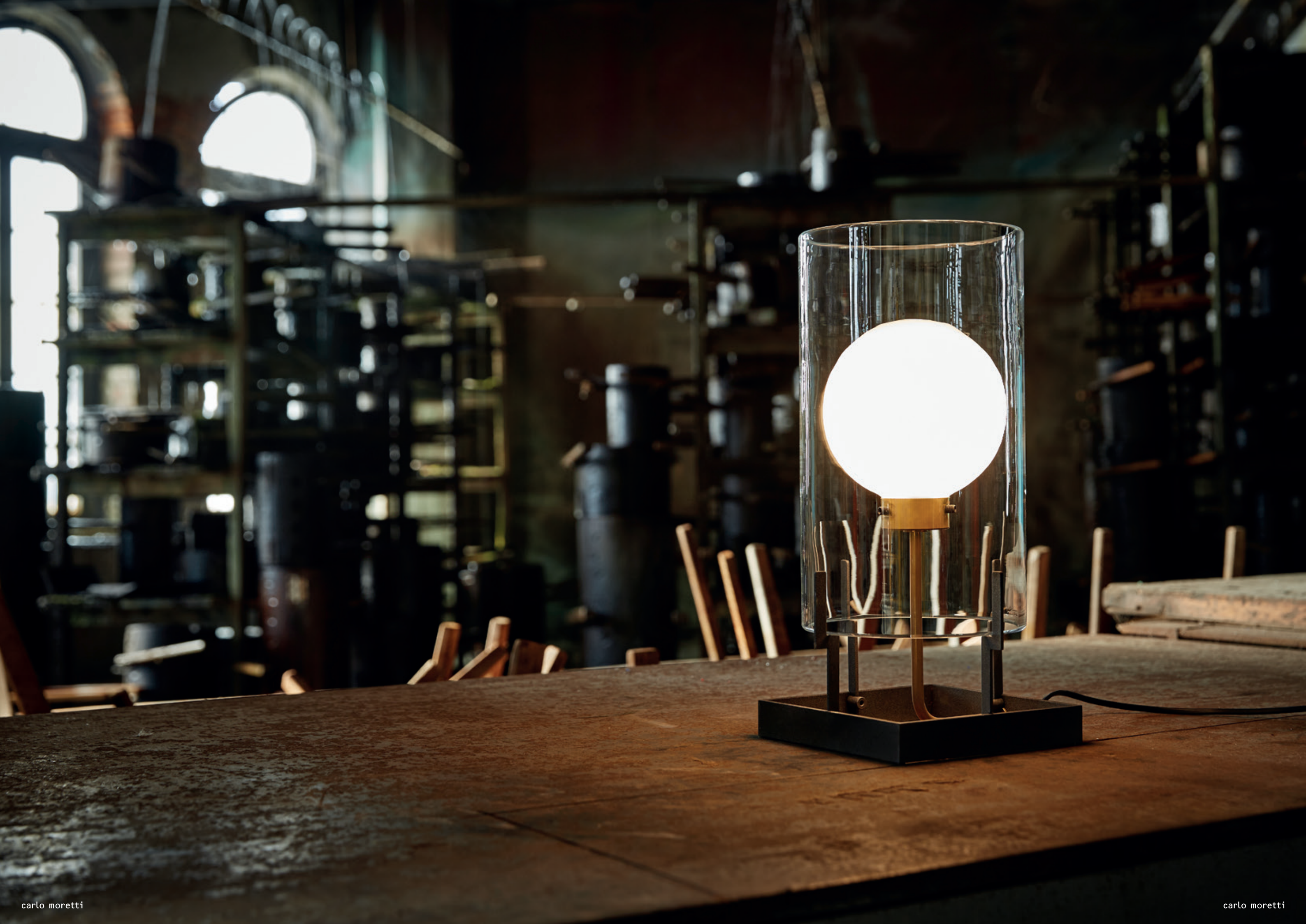





igra

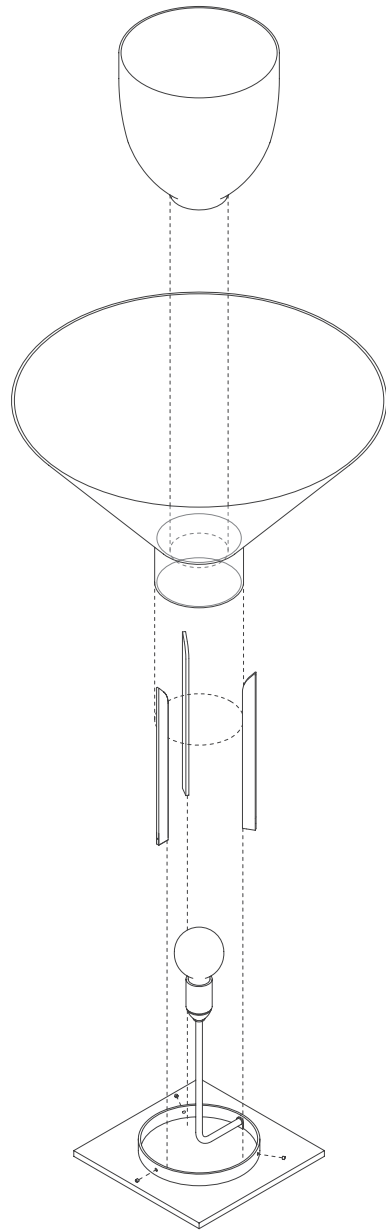

## igra

Oggetto sincero e senza tempo, frutto dell'incontro fra le sensibilità straordinarie di due maestri, combina forme geometriche primarie in vetro con strutture essenziali in metallo, generando equilibri stabili in un gioco di morbide trasparenze e riflessioni.

*A pure, timeless object, the result of an encounter between the extraordinary sensitivity of two masters, combining the primary geometrical shapes in glass with essential structures in metal, generating a stable equilibrium in an interplay of soft transparency and reflections.*

Lampada da tavolo con corpo illuminante in Cristallo di Murano, struttura metallica in ferro verniciato antracite e ottone naturale.

*Table-lamp with Murano Crystal illuminating body, metal structure in anthracite-painted iron and natural brass.*

Carlo Moretti  
con intervento di Paolo Martinuzzi  
1984

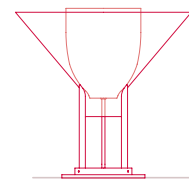

lampada da tavolo  
h. 370 mm  
ø 390 mm  
table lamp  
h. 14.57"  
ø 15.35"

mito











drima

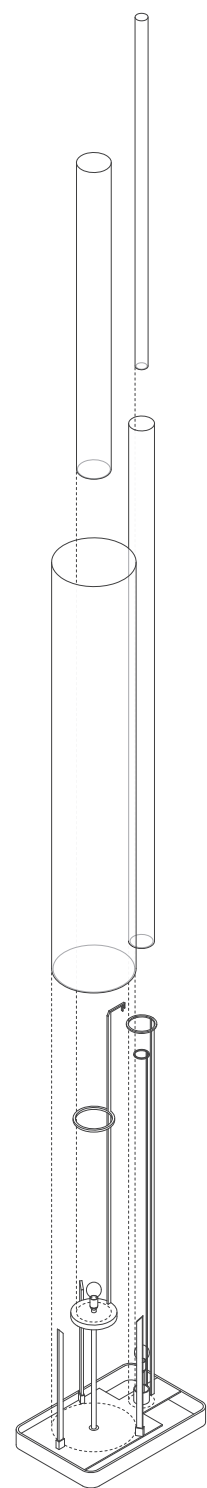

## drima

Frutto dell'incontro fra le sensibilità straordinarie di due maestri, l'oggetto con la sua speciale presenza caratterizza l'ambiente, coniugando affusolati cilindri in vetro di differenti altezze, trasparenti e opalini, con esili sostegni in metallo.

*The fruit of an encounter between two masters with extraordinary sensitivity, with its particular presence this object stands out in its surroundings, combining streamlined transparent and opaline glass cylinders of different heights, with slender metal supports.*

Lampada da terra con corpo illuminante in Cristallo di Murano, struttura metallica in ferro verniciato antracite.

*Floor-lamp with Murano Crystal illuminating body, metal structure in anthracite-painted iron and natural brass.*

Carlo Moretti  
con intervento di Paolo Martinuzzi  
1984

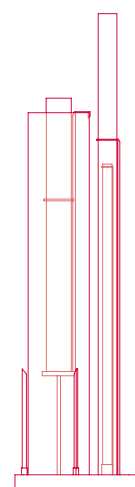

lampada da terra  
h. 1550 mm  
Ø 420 mm  
floor lamp  
h. 61.02"  
Ø 16.54"

mito









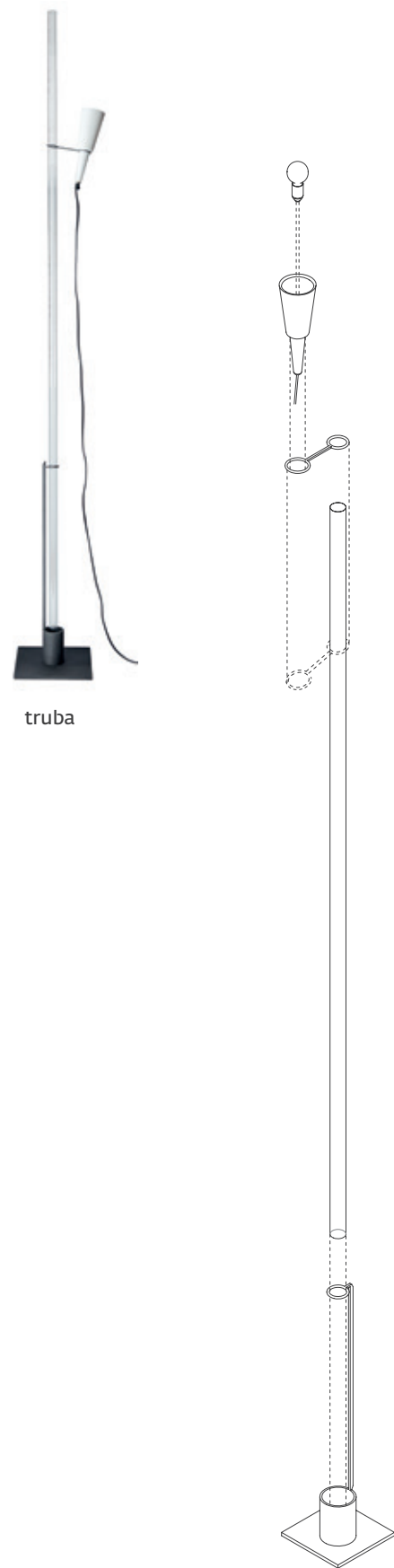

truba

## truba

Ardita ed eterea, la composizione, resa solidale da filiformi giunzioni metalliche, manifesta la doppia natura del vetro come sottile struttura di supporto e puntuale diffusore di luce.

**Bold and ethereal, with the solidity resulting from the thread-like metal junctions, the composition reveals the double nature of glass as a supporting structure and precise light source.**

Lampada da terra con corpo illuminante e sostegno in Cristallo di Murano, corpo illuminante posizionabile a varie altezze, base metallica in ferro verniciato antracite.

**Floor-lamp with Murano Crystal illuminating body and rod, the illuminating body is adjustable in height, metal base in anthracite-painted iron.**

Carlo Moretti  
con intervento di Marco Zanuso jr.  
1984



lampada da terra  
h. 2200 mm  
ø 180 mm  
**floor lamp**  
h. 86.61"  
ø 7.09"

mito











dune



cilla



office



cupola



medusa





094/G



094.0



093.0

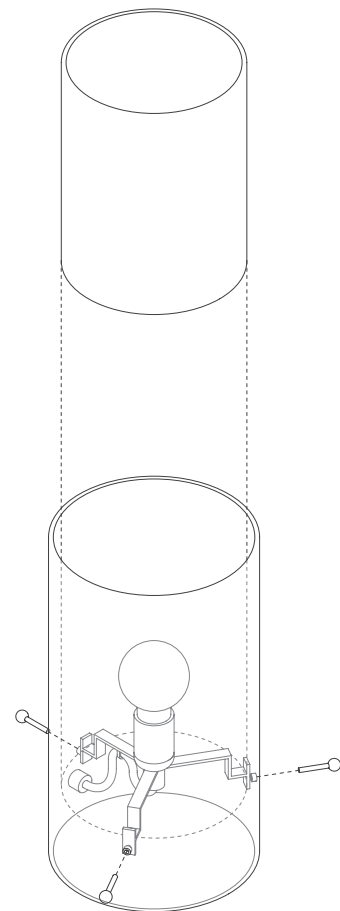

## cilla

Rivisitazione di un progetto rappresentativo della tradizione Carlo Moretti, dedicato all'esplorazione di oggetti funzionali che conservano ed esaltano le peculiarità del vetro muranese. Diafana ed essenziale, esprime purezza, leggerezza e concretezza in una forma intramontabile.

Revival of an exemplary project from the traditional Carlo Moretti repertoire, it is dedicated to the study of functional objects that preserve and exalt the unique characteristics of Murano glass. Delicate and essential, it expresses purity, lightness and concreteness in an everlasting form.

Lampada da tavolo in Cristallo di Murano con montatura in ottone cromato e cilindri in vetro trasparente e opalino.

Table lamp in Murano Crystal with chromed brass fixture and transparent and opaline glass cylinders.

Carlo Moretti  
1993

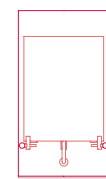

lampada  
da tavolo  
h. 365 mm  
Ø 203 mm  
table lamp  
h. 14.37"  
Ø 7.99"

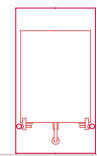

lampada  
da tavolo  
h. 320 mm  
Ø 180 mm  
table lamp  
h. 12.60"  
Ø 7.09"

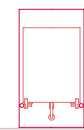

lampada  
da tavolo  
h. 260 mm  
Ø 155 mm  
table lamp  
h. 10.24"  
Ø 6.10"

dune











L.197.E

## office

Oggetto rappresentativo della tradizione Carlo Moretti reso contemporaneo dall'impiego di cristallo e vetro lattimo capace di restituire effetti luminosi caldi e soffusi. Dalla fusione fra base, fusto e diffusore in un *unicum* bianco origina la morbida forma organica che evoca l'ambiente lagunare.

An exemplary object from the traditional Carlo Moretti repertoire modernised with the use of transparent and milky white glass that creates warm, soft light effects. The soft organic form evoking the lagoon surroundings is the result of the fusion between its base, column and diffuser in a unique white object.

Lampada da tavolo in Cristallo di Murano soffiata a bocca e rifinita a mano color bianco latte.

Table lamp in Murano Crystal, blown by mouth and hand-finished, milk white colour.

Carlo Moretti  
1994

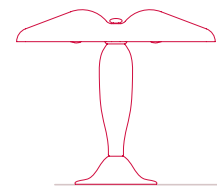
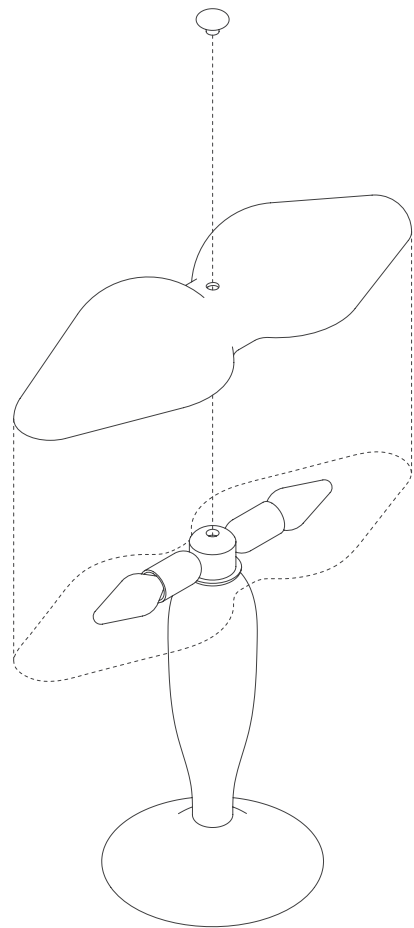

lampada da tavolo  
h. 380 mm  
Ø 400 mm  
table lamp  
h. 14.96"  
Ø 15.75"

dune











L.292.E



L.092.E

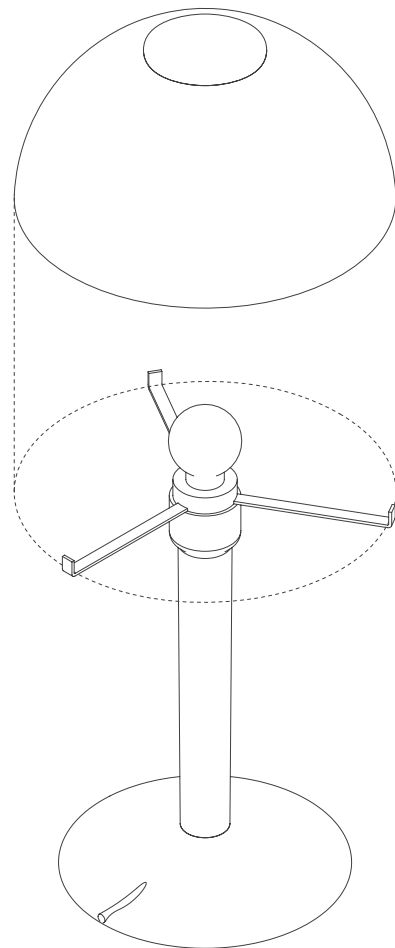

## cupola

Venezia è anche una città di cupole – scriveva Carlo Moretti – raccontando questo classico intramontabile. Di estrema eleganza, traduce la perfezione geometrica di un archetipo architettonico in un artefatto in grado di ripercorrere tracce della cultura aziendale nei linguaggi essenziali della contemporaneità.

*Describing this everlasting classic, Carlo Moretti once wrote that Venice is also a city of cupolas. Extremely elegant, it expresses the geometric perfection of an architectural archetype in an object that embodies the business culture in the essential language of contemporary times.*

Lampada da tavolo in Cristallo di Murano bianco latte.

*Table lamp in Murano Crystal in milk white.*

Carlo Moretti  
1992

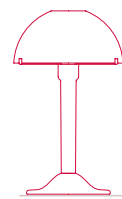

lampada  
da tavolo  
h. 400 mm  
ø 240 mm  
table lamp  
h. 15.75"  
ø 9.45"

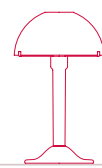

lampada  
da tavolo  
h. 330 mm  
ø 180 mm  
table lamp  
h. 12.99"  
ø 7.09"

dune











050.A



050.B

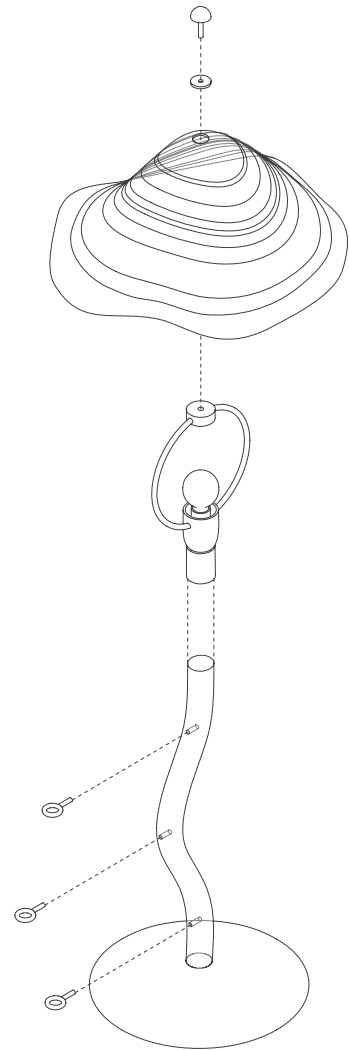

Progetto ardito e sperimentale dall'inedito equilibrio, è la dimostrazione delle virtuose abilità dei maestri muranesi che coniuga il sinuoso supporto trasparente con la plasticità e la raffinatezza cromatica del diffusore.

**A bold, experimental project of innovative equilibrium, it is testimony to the virtuos skill of the Murano masters who combine the sinuous transparent support with the plasticity and chromatic elegance of the diffuser.**

Lampada da tavolo con stelo e base in Cristallo di Murano trasparente. Paralume in cristallo satinato eseguito a mano libera con spirali in due versioni di colore.

**Table lamp with rod and base in transparent Murano Crystal. Satin crystal shade made with free hand technique with spirals in two different colours.**

Carlo Moretti  
1996

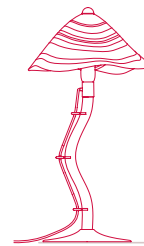

lampada da tavolo  
h. 508 mm  
Ø 260 mm  
**table lamp**  
h. 20"  
Ø 10.24"

dune











isole

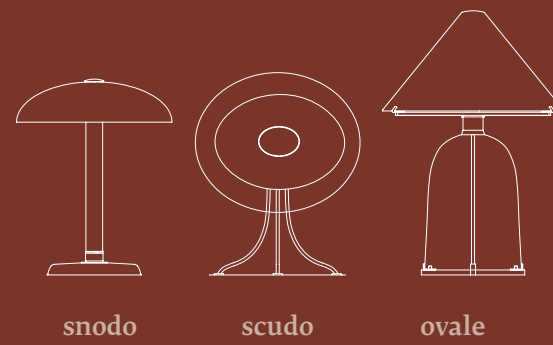





002.81

## snodo

Declinazione in vetro di Murano del design degli apparecchi illuminanti, l'oggetto dimostra la grande attenzione nei confronti della costruzione della luce che, direzionata, schermata e diffusa, racconta le qualità peculiari della materia.

An example in Murano glass of lighting equipment design, that pays particular attention to the construction of light that, directed, shaded and diffused, expresses the unique characteristics of the material.

Lampada da tavolo orientabile in Cristallo di Murano lattimo. Montatura in cromo lucido.

Adjustable table lamp in milky glass Murano Crystal. Fixture in polished chrome.

Carlo Moretti  
1978

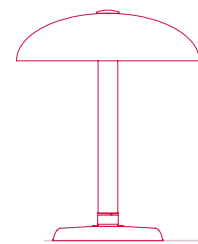
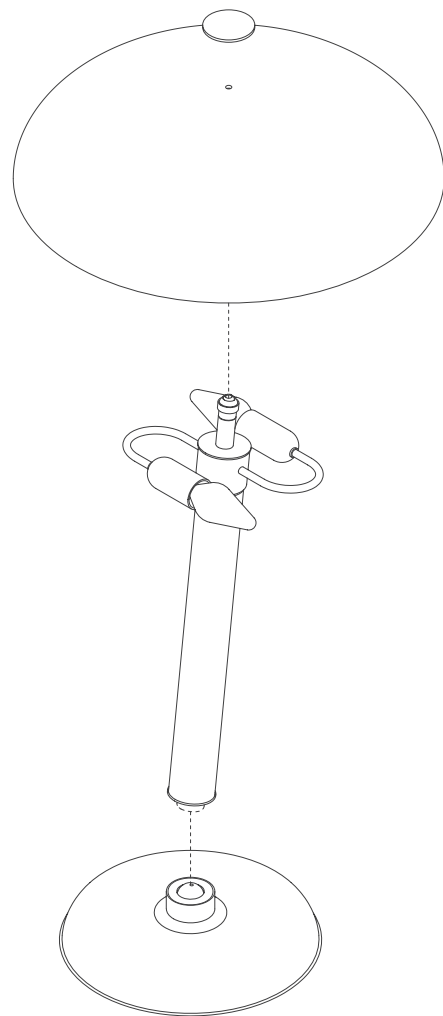

lampada da tavolo  
h. 500 mm  
ø 395 mm  
table lamp  
h. 19.69"  
ø 15.55"

isole











scudo

## scudo

Declinazione in vetro di Murano del design degli apparecchi illuminanti, l'oggetto dimostra la grande attenzione nei confronti della costruzione della luce che, schermata e diffusa, evidenzia gli equilibrati contrasti resi possibili dalla lavorazione del materiale.

An example in Murano glass of lighting equipment design, that pays particular attention to the construction of light that, directed, shaded and diffused, expresses the unique characteristics of the material.

Lampada da tavolo con base a tre steli in cromo lucido e paralume piatto verticale realizzato a mano in Cristallo di Murano trasparente e satinato nella complessa tecnica della mano volante.

Table lamp with three-rod base in polished chrome and flat vertical shade hand made in transparent and polished Murano Crystal using the sophisticated 'mano volante' technique.

Carlo Moretti  
2002

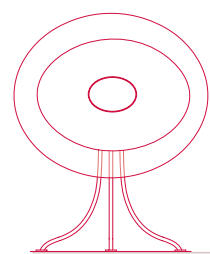

lampada da tavolo  
h. 520 mm  
Ø 440 mm  
table lamp  
h. 20.47"  
Ø 17.32"

isole





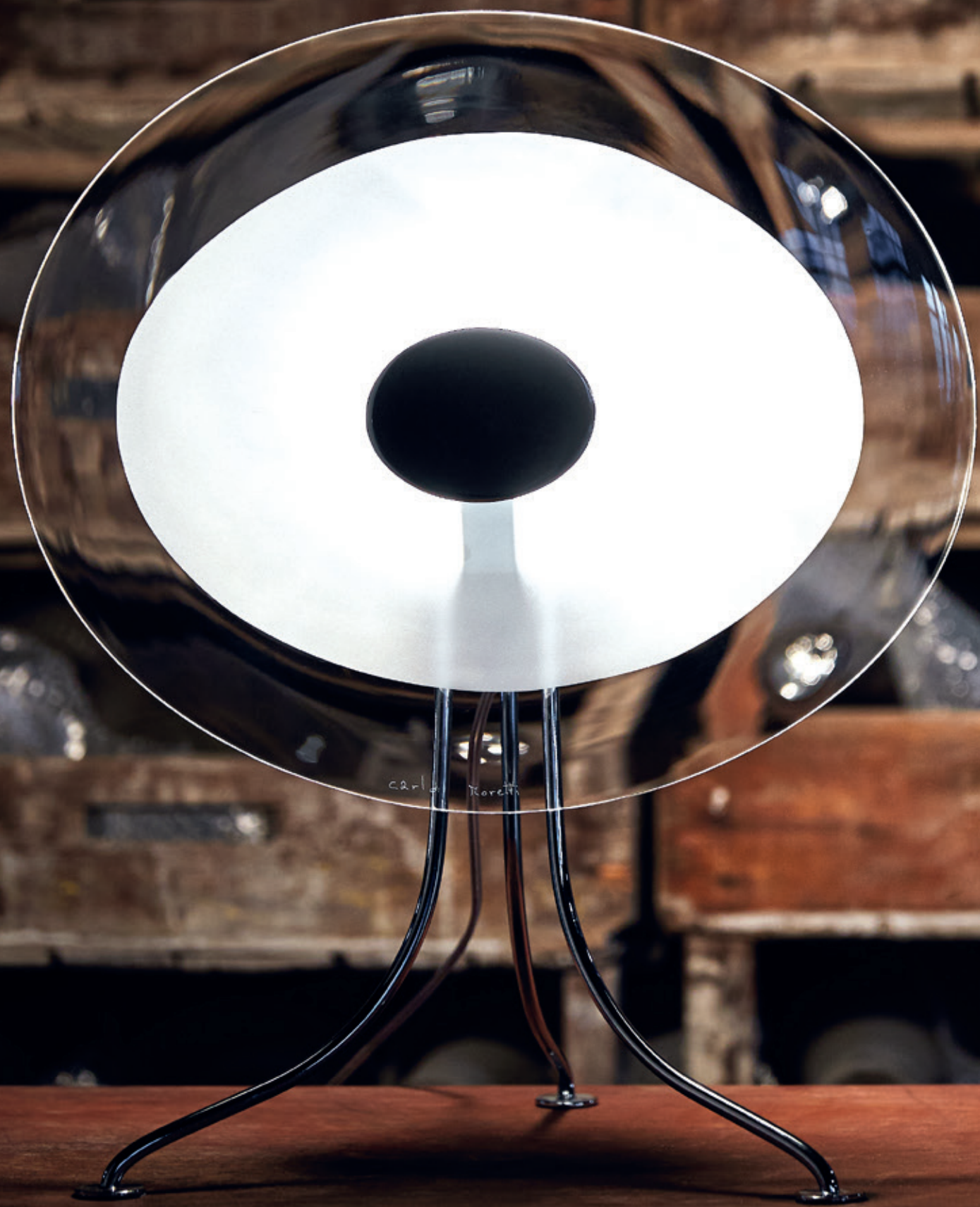





95.OPC



95.OPD

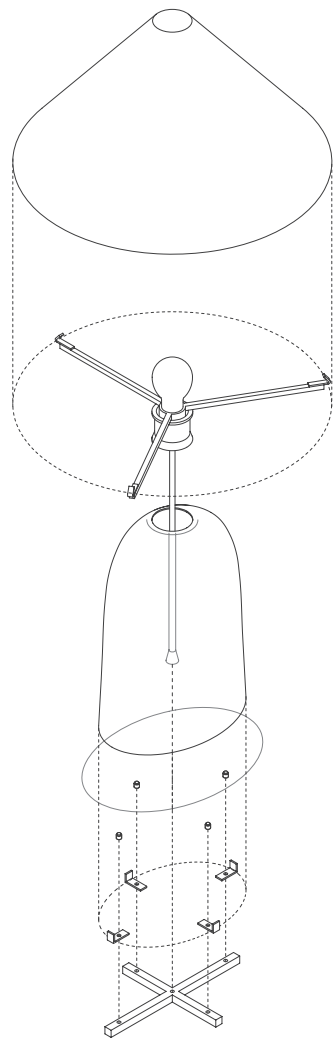

Declinazione in vetro di Murano del design degli apparecchi illuminanti, l'oggetto dimostra la grande attenzione nei confronti della costruzione della luce giocando sul contrasto fra lucido e opaco, trasparente e opalino, etereo e concreto.

An example in Murano glass of lighting equipment design, that pays particular attention to the construction of light, highlighting the contrast between bright and opaque, transparent and opaline, ethereal and concrete.

Lampada da tavolo in Cristallo di Murano con base trasparente o nera opalina, paralume in vetro bianco opalino e montatura in metallo dorato o cromo lucido.

Table lamp in Murano Crystal with transparent base and opaline black, the white opaline glass shade is mounted on gilded metal or polished chrome.

Carlo Moretti  
1983

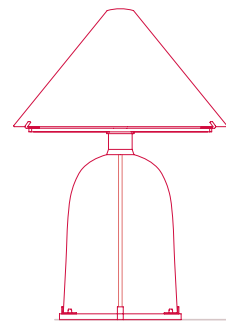

lampada da tavolo  
h. 690 mm  
Ø 480 mm  
table lamp  
h. 27.17"  
Ø 18.90"

isole











maree



faro

bricola





074.LG



074.RN

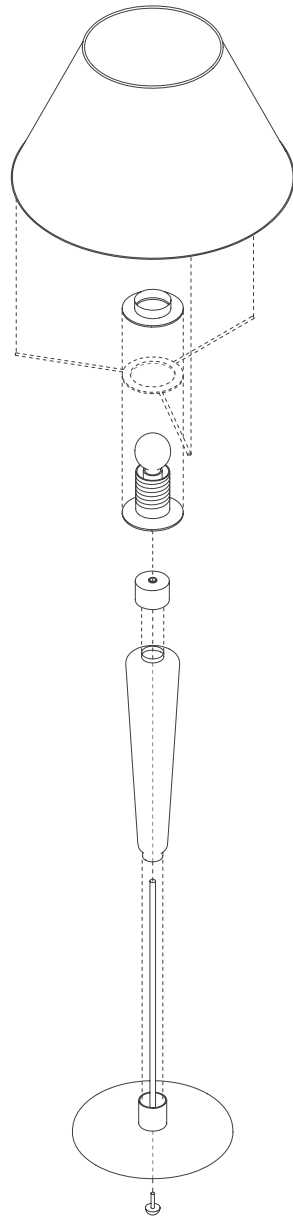

L'impianto classico della lampada è impreziosito dal disegno a fili incrociati dello stelo che, alternando trasparenze e cromatismi, amplifica ombre e riflessioni nell'ambiente.

The classic structure of this lamp is enhanced by the criss-crossed thread pattern on the rod that, with an alternation of transparent and chromatism amplifies the shadows and reflections around it.

Lampada da tavolo di dimensioni importanti con stelo in Cristallo di Murano con spirale grigio in pasta e lattimo o nera e corallo. Base in cristallo trasparente e paralume in tessuto a forma troncoconica. Montatura metallica con finitura in cromo lucido.

A table lamp of considerable dimensions with a Murano Crystal column and grey/white or black/coral spiral. Transparent glass base and a truncated-cone shaped fabric shade. Metal fixture in polished chrome.

Carlo Moretti  
2003

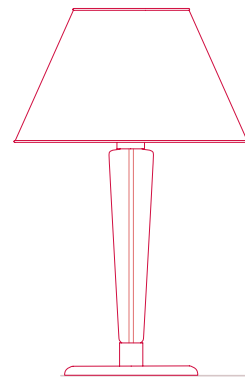

lampada da tavolo  
h. 790 mm  
Ø 480 mm  
table lamp  
h. 31.10"  
Ø 18.90"

maree







072.A



072.B



072.LG

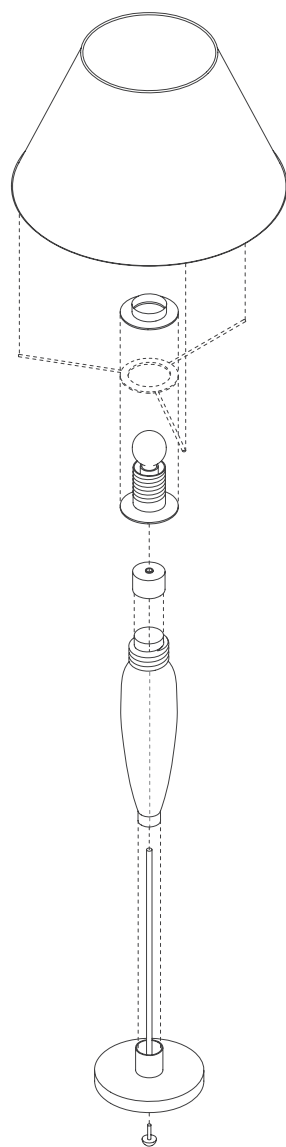

L'impianto classico della lampada è impreziosito dal disegno a fili incrociati dello stelo che, alternando trasparenze e cromatismi, amplifica ombre e riflessioni nell'ambiente.

The classic structure of this lamp is enhanced by the pattern of criss-crossed threads on the rod that, with an alternation of transparent and chromatism amplifies the shadows and reflections in its surroundings.

Lampada da tavolo di dimensioni importanti con stelo in Cristallo di Murano con spirale nera e corallo, rosso e corallo o grigio e lattimo. Base in cristallo trasparente e paralume in tessuto a forma troncoconica. Montatura metallica con finitura in cromo lucido.

A table lamp of considerable dimensions with a MuranoCrystal stand and black/coral, red/coral or grey/white spiral. Transparent glass base and a truncated-cone shaped fabric shade. Metal fixture in polished chrome.

Carlo Moretti  
1995

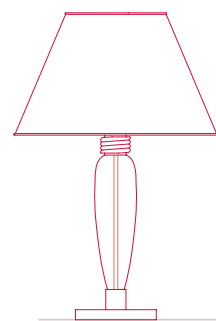

lampada da tavolo  
h. 670 mm  
Ø 480 mm  
table lamp  
h. 26.37"  
Ø 18.90"

maree







lumina



led.polari

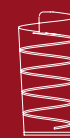

led.nastrino





led.polari

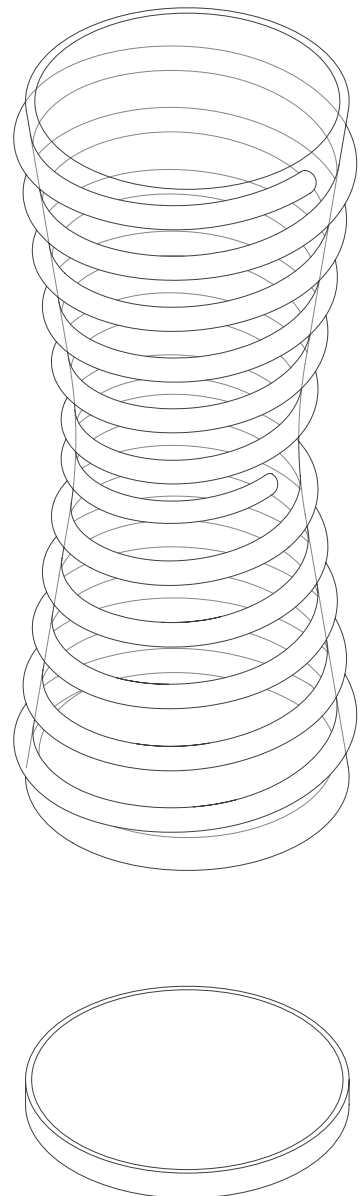

## led.polari

L'originale oggetto coniuga l'adozione di una sorgente luminosa led, collocata alla base, con la valorizzazione di uno dei capolavori della produzione Carlo Moretti che, oltre a mantenere la funzione di vaso, è disvelato grazie agli effetti luminosi di rifrazione e trasparenza.

The original object combines the use of a led light source at the base, with the enhancement of one of the masterpieces from the Carlo Moretti production that not only acts as a vase, but is also revealed thanks to the light effects of refraction and transparency.

Lampada da tavolo con corpo illuminante costituito da un vaso Carlo Moretti in Cristallo di Murano, soffiato a bocca e rifinito a mano, con applicazioni a caldo di elementi decorativi. Base illuminante costituita da un disco in alluminio con incorporata sorgente led.

Table lamp with an illuminated body made of a Carlo Moretti vase in Murano Crystal, blown by mouth, hand finished, with hot application of decorative elements. Illuminated base made of an aluminium disc led source incorporated.

Carlo Moretti  
2012 PATENTED

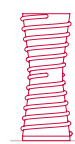

lampada da tavolo  
h. 270 mm  
Ø 102 mm  
table lamp  
h. 10.63"  
Ø 4.02"

lumina











led.nastrino

## led.nastrino

L'originale oggetto coniuga l'adozione di una sorgente luminosa led, collocata alla base, con la valorizzazione di una delle pietre miliari della storia aziendale, il Cartoccio, che, oltre a mantenere la funzione di vaso, è disvelato grazie agli effetti luminosi di rifrazione e trasparenza.

The original object combines the use of a led light source at the base, with the enhancement of one of the masterpieces from the Carlo Moretti production, the Cartoccio, which not only acts as a vase, but is also revealed thanks to the light effects of refraction and transparency.

Lampada da tavolo con corpo illuminante costituito da una reinterpretazione di "Cartoccio", vaso Carlo Moretti in Cristallo di Murano, a sezione rotonda e soffiato a bocca, intagliato a mano libera con mola diamantata. Base illuminante costituita da un disco in alluminio con incorporata sorgente led.

Table lamp with illuminated body made from a reworking of Cartoccio, a Carlo Moretti vase in Murano Crystal, with a round section and blown by mouth, with diamond wheel mano libera engraving. Illuminated base made of an aluminium disc led source incorporated.

Carlo Moretti  
2012 PATENTED



lampada da tavolo  
h. 265 mm  
Ø 130 mm  
table lamp  
h. 10.43"  
Ø 5.12"

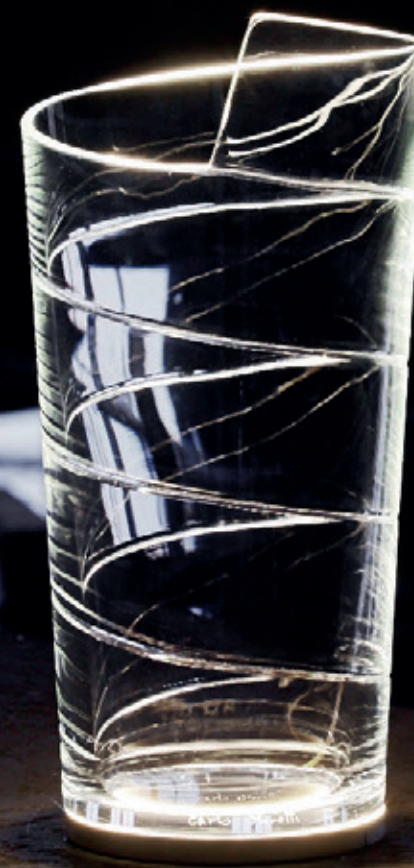
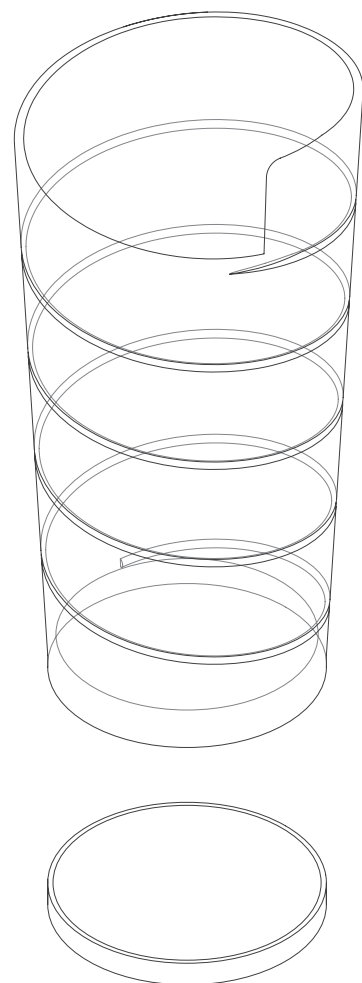



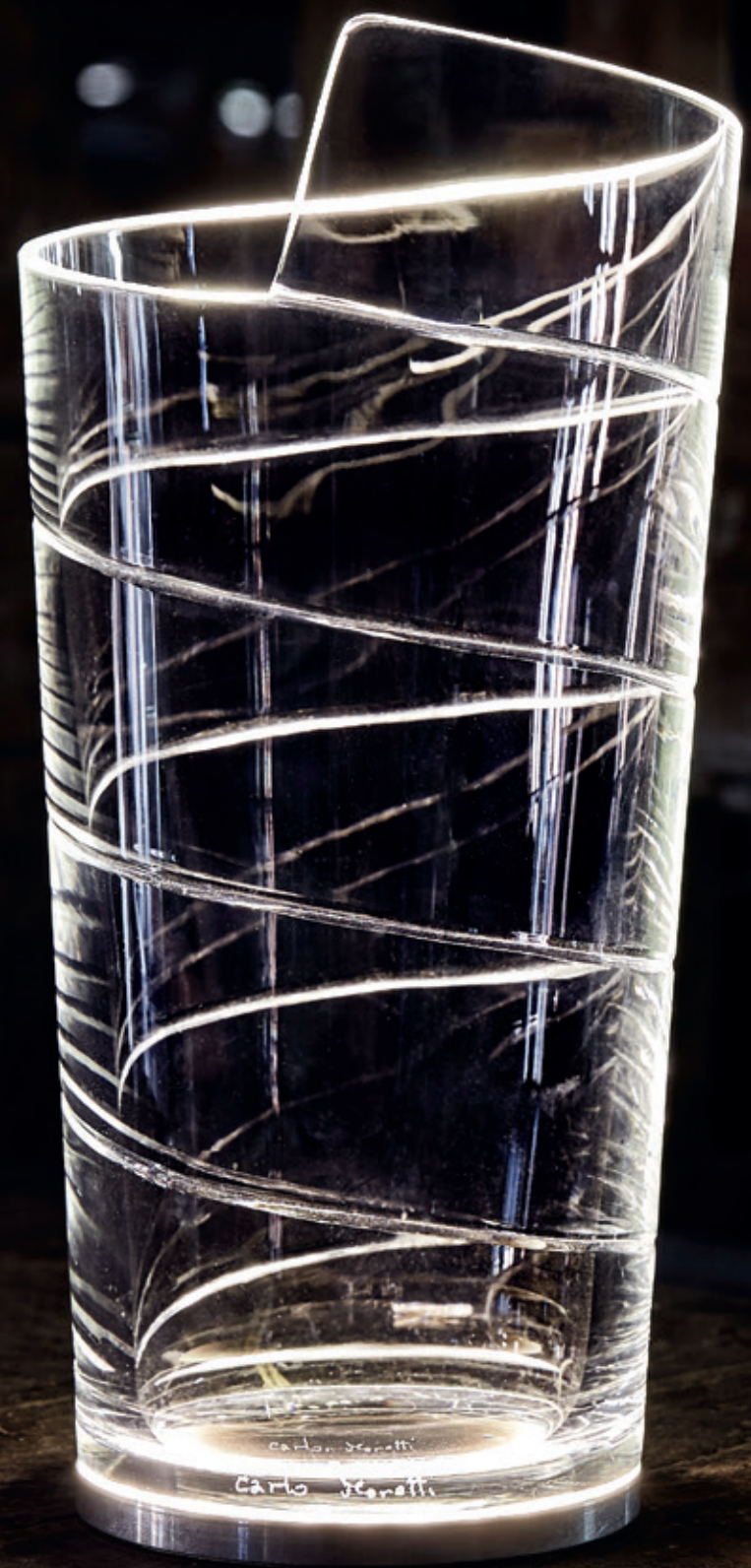





contract project





















Reinterpretazione del classico globo di luce e destinata al contract-lighting più esigente, la scenografica soluzione personalizza composizioni dinamiche in cui l'effetto di leggerezza della sospensione è ottenuto dalla combinazione fra la trasparenza del cristallo e la morbida luce irradiata dal vetro bianco lattimo.

Progetto sviluppato in collaborazione con Diego Chilò, uno degli interpreti del lighting-design contemporaneo.

**A reworking of the classic light globe used for the most demanding contract-lighting, the set solution personalises dynamic compositions in which the effect of the lightness of suspension is achieved thanks to the combination of the transparency of the glass and the soft light coming from the milk white glass.**

**Project developed together with Diego Chilò, one of the interpreters of contemporary lighting design.**

Sistema personalizzabile di lampade a sospensione costituito da sfere in Cristallo di Murano. Alimentatore escluso, fornito a parte in base al numero di sfere. Possibilità di dimmerabilità e interfacciamento domotico.

**Personalised hanging lamp system, with Murano Crystal. Electronic ballast not included, it is supplied separately depending on the number of the spheres. Technical features of dimmability and domotic interface.**

Carlo Moretti  
2015



lampada  
a sospensione  
h. 100 mm  
ø 100 mm  
**suspension  
lamp**  
h. 3.94"  
ø 3.94"

lampada  
a sospensione  
h. 140 mm  
ø 140 mm  
**suspension  
lamp**  
h. 5.51"  
ø 5.51"

lampada  
a sospensione  
h. 180 mm  
ø 180 mm  
**suspension  
lamp**  
h. 7.09"  
ø 7.09"

contract project





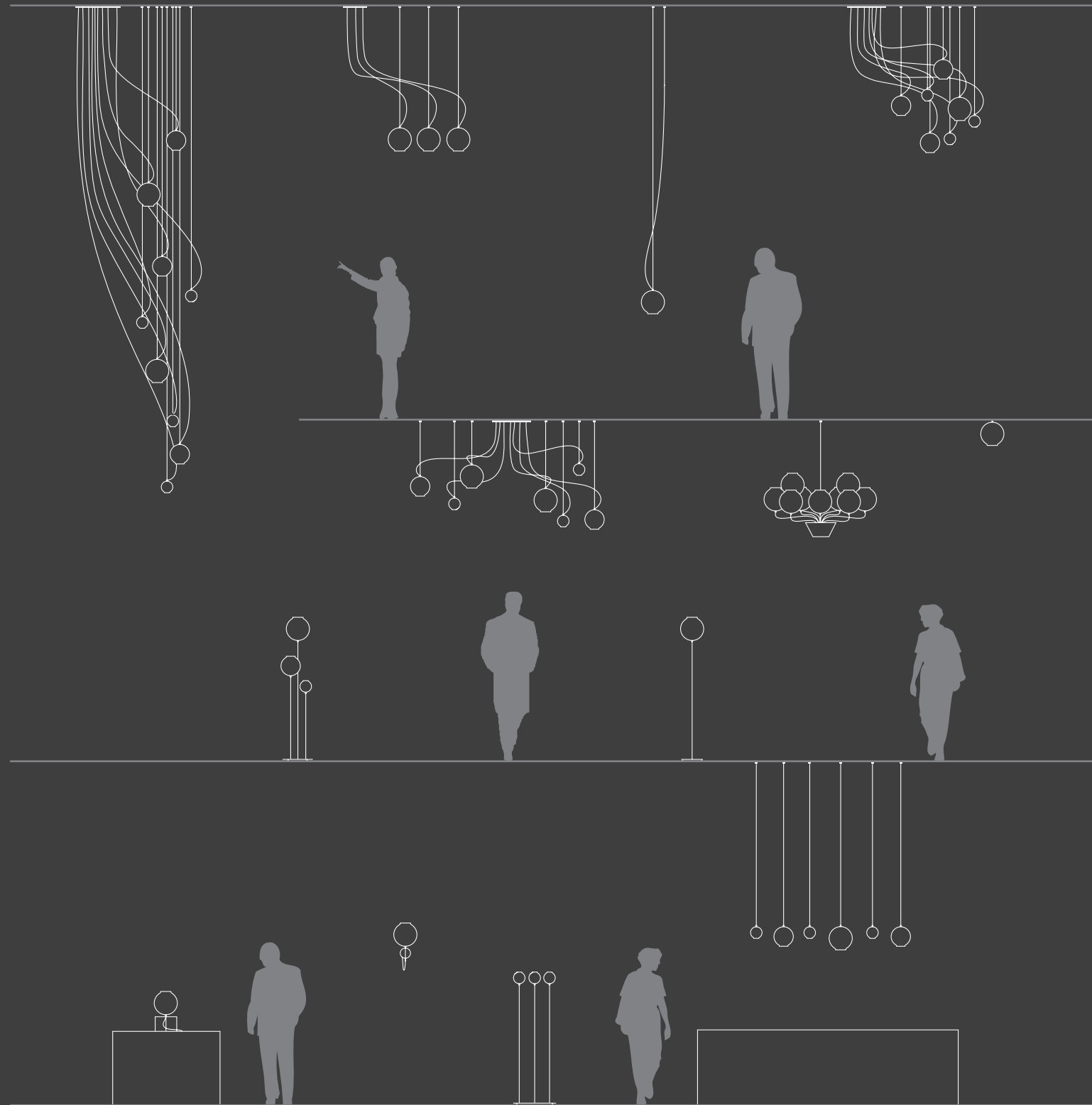





801.810.F



801.810.G

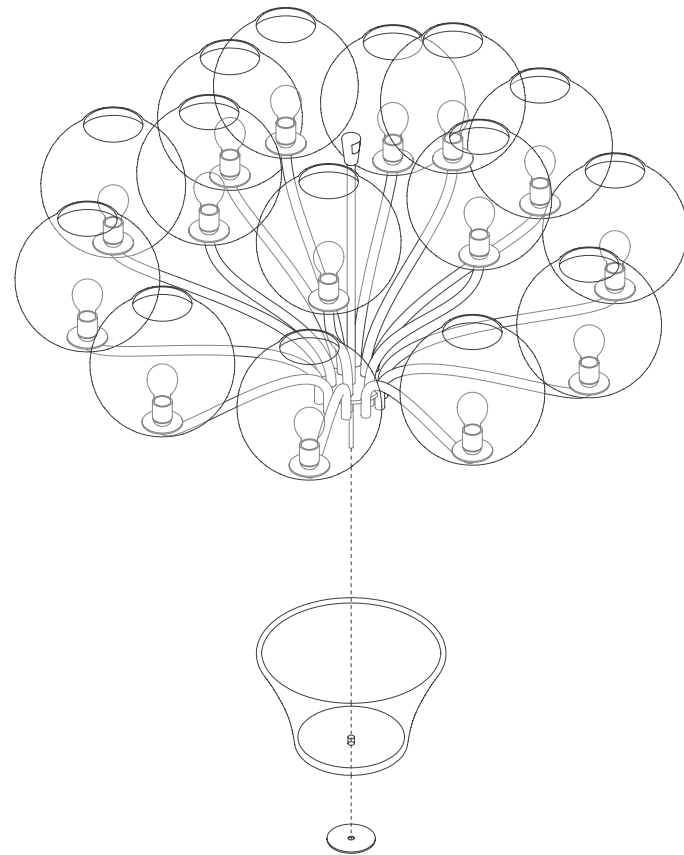

Declinazione del progetto Boblu, rivisita in chiave contemporanea il lampadario veneziano combinando geometrie primarie sapientemente decorate con caldi e morbidi effetti luminosi irradiati dal vetro bianco lattimo.

*A variation of the Boblu project, this is a contemporary interpretation of the Venetian lamp, combining primary geometries that are skillfully decorated with soft, warm light effects coming from the milk white glass.*

Lampadario costituito da sfere decorate in Cristallo e vetro lattimo di Murano con decorazioni in rosso o grigio in pasta, montate su bracci in metallo con finitura in cromo satinato convergenti in un elemento centrale in vetro.

*Chandelier made of decorated spheres in Murano Crystal and milk glass with red or grey opaque decorations on metal arms with satin chrome finishing that converge in a central glass element.*

A richiesta la decorazione delle sfere può essere personalizzata su progetto.  
*The decoration of the spheres can be personalised upon request.*

Carlo Moretti  
2014

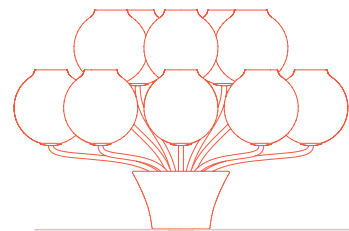

lampadario  
h. 527 mm  
ø 810 mm  
chandelier  
h. 20.75"  
ø 31.89"











cm

custom projects



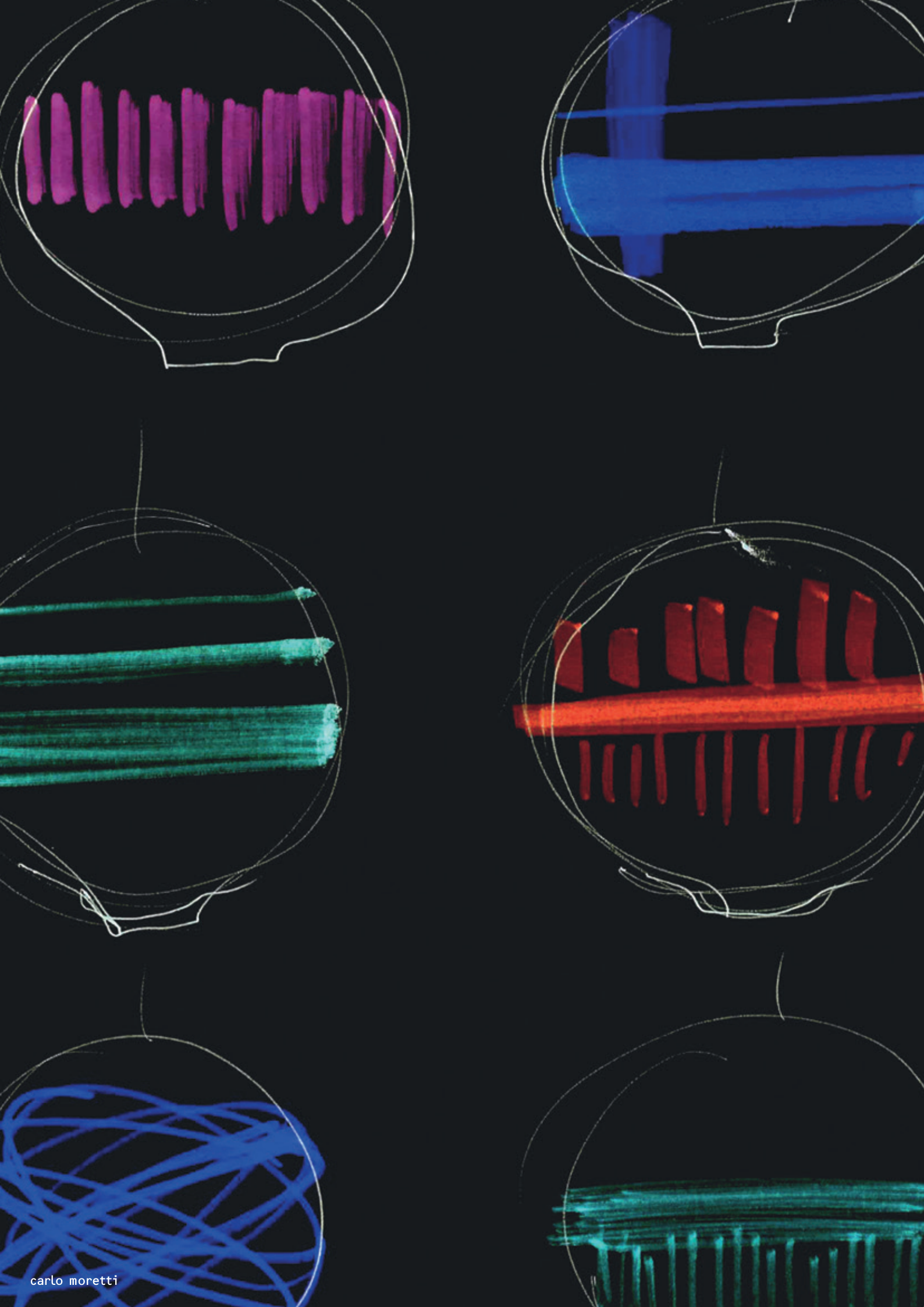

- **PROGETTO**

Carlo Moretti interpreta e personalizza le peculiari esigenze del mercato custom mettendo a disposizione di imprese e istituzioni private e pubbliche – come quelle che operano nei settori accoglienza, ristorazione, retail o uffici –, la professionalità e l'esperienza di un team di progettazione altamente specializzato, la sensibilità e le competenze di maestri vetrai affermati, la flessibilità produttiva e la struttura organizzativa di un'azienda consolidata.

- **RICERCA**

La conoscenza dei comportamenti dei materiali unita alla capacità esecutiva Carlo Moretti permettono di approdare a risultati tecnici in grado di risolvere, caso per caso, i punti critici di ciascun progetto. In appositi confronti tecnici interdisciplinari sono approfondite e sviluppate le questioni poste dai clienti, nei quali, oltre al confronto sulle soluzioni tecnologiche, sono verificate la fattibilità dell'oggetto e degli effetti luminosi proposti.

- **DETTAGLI**

L'identità del prodotto finito è analiticamente rappresentata nei disegni tecnici costruttivi elaborati dal team Carlo Moretti che sintetizzano e racchiudono con precisione la molteplicità degli aspetti da considerare in fase di realizzazione. Un efficace strumento di riscontro in cui, simultaneamente, trovano espressione modalità di funzionamento e valori estetici, prestazioni di altissima qualità e rispetto delle normative sulla sicurezza.

- **CONCEPT**

Carlo Moretti interprets and personalises the particular needs of the market including both private and public companies and institutions, such as those working in the sectors of tourism reception, catering, retail or offices: it offers them the professionalism and experience of a highly specialised design team, the sensitivity and competence of established glass makers, production flexibility and the organised structure of a well-established company.

- **STUDY**

The combination of a sound knowledge of material behaviour and the operational skill of Carlo Moretti are a guarantee for technical results that are able to resolve the critical points of each project. The client's questions are dealt with from an interdisciplinary perspective of all technical aspects when, in addition to a comparison of possible technological solutions, the feasibility of the object and the proposed light effects are also assessed.

- **DETAILS**

The identity of the finished product is analytically portrayed in the technical construction designs elaborated by the Carlo Moretti team, summarising all the multiple aspects that need to be taken into account during the implementation phase. This is an effective instrument that not only includes details of the functioning mode and aesthetical values, high quality performance and compliance with all safety regulations.





- **CONTROLLO QUALITÀ**

Carlo Moretti assicura ai suoi clienti il pieno controllo dell'intero processo di progettazione e realizzazione dei prodotti. Esamina e verifica rigorosamente i suoi prodotti con controlli qualitativi in ogni fase di lavorazione coniugando l'arte e la tecnica dei maestri vetrai muranesi con la perfezione esecutiva delle componenti tecnologiche e meccaniche.

- **LOGISTICA**

Il totale controllo della produzione Carlo Moretti si estende alle ulteriori fasi di gestione del processo di compimento del progetto. Al fine di evitare eventuali danneggiamenti, packaging, trasporto e distribuzione sono infatti oggetto di una rigorosa e attenta elaborazione e programmazione mirate alla perfetta conservazione e al mantenimento dell'integrità del prodotto finale.

- **ALLESTIMENTO**

In diretto accordo con il cliente, a garanzia del risultato finale, Carlo Moretti gestisce con estrema accuratezza l'installazione di tutti i suoi prodotti; un team di tecnici specializzati si occupa di definire e di predisporre strutture e supporti specifici seguendo, caso per caso, le apposite normative e disposizioni per la sicurezza del cantiere.

- **QUALITY CONTROL**

Carlo Moretti guarantees its clients total control over the entire design and creation process of the products. Its products undergo qualitative controls during each stage of the production process, in which the technique of the Murano glass masters goes hand in hand with the operational perfection of the technological and mechanical components.

- **LOGISTICS**

The complete control of Carlo Moretti's production includes the last stages of managing the completion process of the project. In order to avoid any damage, the packaging, transport and distribution are subjected to rigorous elaboration and planning, to guarantee the perfect conservation and integrity of the final product.

- **INSTALLATION**

To guarantee the final product, in direct agreement with the client, Carlo Moretti manages the installation of all its products paying the greatest attention to deal; a team of specialised technicians is in charge of the definition and arrangement of structures and specific supports, in accordance with the relevant regulations and provisions on worksite safety.





inventario tecnico  
appendici





**bricola**  
1995

maree

**072.A**

lampada da tavolo

*dimensioni*  
h. 670 mm  
Ø 480 mm  
*peso*  
4,10 kg.

*lampadine*  
60 W incandescenza  
42 W ecolamp  
*attacco*  
E27  
dimmerabile

*vetro*  
base: cristallo trasparente  
stelo: cannette nere /  
spirale rossa  
*metallo*  
cromo lucido  
*diffusore*  
tessuto

table lamp

*dimensions*  
h. 26.37"  
Ø 18.90"  
*weight*  
4,10 kg.

*light bulbs*  
60 W incandescent lamp  
42 W ecolamp  
*socket*  
E27 - dimmable

*glass*  
base: transparent crystal  
stem: crystal with little rods  
black/spiral red  
*metal type*  
polished chrome  
*shade*  
fabric

**p. 76**



**bricola**  
1995

maree

**072.B**

lampada da tavolo

*dimensioni*  
h. 670 mm  
Ø 480 mm  
*peso*  
4,10 kg.

*lampadine*  
60 W incandescenza  
42 W ecolamp  
*attacco*  
E27  
dimmerabile

*vetro*  
base: cristallo trasparente  
stelo: cristallo con  
cannette rosse / spirale nera  
*metallo*  
cromo lucido  
*diffusore*  
tessuto

table lamp

*dimensions*  
h. 26.37"  
Ø 18.90"  
*weight*  
4,10 kg.

*light bulbs*  
60 W incandescent lamp  
42 W ecolamp  
*socket*  
E27 - dimmable

*glass*  
base: crystal  
stem: crystal with little rods  
red/spiral black  
*metal type*  
polished chrome  
*shade*  
fabric

**p. 76**



**bricola**  
1995

maree

**072.LG**

lampada da tavolo

*dimensioni*  
h. 670 mm  
Ø 480 mm  
*peso*  
4,10 kg.

*lampadine*  
60 W incandescenza  
42 W ecolamp  
*attacco*  
E27  
dimmerabile

*vetro*  
base: cristallo trasparente  
stelo: cristallo con  
cannette grigie / spirale lattimo  
*metallo*  
cromo lucido  
*diffusore*  
tessuto

table lamp

*dimensions*  
h. 26.37"  
Ø 18.90"  
*weight*  
4,10 kg.

*light bulbs*  
60 W incandescent lamp  
42 W ecolamp  
*socket*  
E27 - dimmable

*glass*  
base: crystal  
stem: crystal with little  
grey rods/spiral white  
*metal type*  
polished chrome  
*shade*  
fabric

**p. 76**



**cilla**  
1993

dune

**093.0**

lampada da tavolo

*dimensioni*  
h. 260 mm  
Ø 155 mm  
*peso*  
1,70 kg.

*lampadine*  
60 W incandescenza  
42 W ecolamp  
*attacco*  
E14

*vetro*  
cristallo trasparente/  
cristallo satinato  
*metallo*  
ottone cromato  
*diffusore*  
cristallo satinato

table lamp

*dimensions*  
h. 10.24"  
Ø 6.10"  
*weight*  
1,70 kg.

*light bulbs*  
60 W incandescent lamp  
42 W ecolamp  
*socket*  
E14

*glass*  
transparent crystal/  
glazed crystal  
*metal type*  
chromed brass  
*shade*  
glazed crystal

**p. 42**



**cilla**  
1993

dune

**094.0**

lampada da tavolo

*dimensioni*  
h. 320 mm  
Ø 180 mm  
*peso*  
2,20 kg.

*lampadine*  
60 W incandescenza  
42 W ecolamp  
*attacco*  
E27

*vetro*  
cristallo trasparente/  
cristallo satinato  
*metallo*  
ottone cromato  
*diffusore*  
cristallo satinato

table lamp

*dimensions*  
h. 12.60"  
Ø 7.09"  
*weight*  
2,20 kg.

*light bulbs*  
60 W incandescent lamp  
42 W ecolamp  
*socket*  
E27

*glass*  
transparent crystal/  
glazed crystal  
*metal type*  
chromed brass  
*shade*  
glazed crystal

**p. 42**



**cilla**  
1993

dune

**094/G**

lampada da tavolo

*dimensioni*  
h. 365 mm  
Ø 203 mm  
*peso*  
4,50 kg.

*lampadine*  
60 W incandescenza  
42 W ecolamp  
*attacco*  
E27

*vetro*  
cristallo trasparente/  
cristallo satinato  
*metallo*  
ottone cromato  
*diffusore*  
cristallo satinato

table lamp

*dimensions*  
h. 14.37"  
Ø 7.99"  
*weight*  
4,50 kg.

*light bulbs*  
60 W incandescent lamp  
42 W ecolamp  
*socket*  
E27

*glass*  
transparent crystal/  
glazed crystal  
*metal type*  
chromed brass  
*shade*  
glazed crystal

**p. 42**



**cupola**  
1992

dune

**L.092.E**

lampada da tavolo

*dimensioni*  
h. 330 mm  
Ø 180 mm  
*peso*  
1,50 kg.

*lampadine*  
60 W incandescenza  
42 W ecolamp  
*attacco*  
E14

*vetro*  
bianco latte  
*metallo*  
cromo sabbiato  
*diffusore*  
bianco latte

table lamp

*dimensions*  
h. 12.99"  
Ø 7.09"  
*weight*  
1,50 kg.

*light bulbs*  
60 W incandescent lamp  
42 W ecolamp  
*socket*  
E14

*glass*  
white  
*metal type*  
sanded chrome  
*shade*  
white

**p. 50**



**cupola**  
1992

dune

**L.292.E**

lampada da tavolo

*dimensioni*  
h. 400 mm  
Ø 240 mm  
*peso*  
1,50 kg.

*lampadine*  
60 W incandescenza  
42 W ecolamp  
*attacco*  
E27

*vetro*  
bianco latte  
*metallo*  
cromo sabbiato  
*diffusore*  
bianco latte

table lamp

*dimensions*  
h. 15.75"  
Ø 9.45"  
*weight*  
1,50 kg.

*light bulbs*  
60 W incandescent lamp  
42 W ecolamp  
*socket*  
E27

*glass*  
white  
*metal type*  
sanded chrome  
*shade*  
white

**p. 50**





**drima**  
1984

mito

**drima**

lampada da terra

*dimensioni*  
h. 1550 mm  
Ø 420 mm  
*peso*  
20 kg.

*lampadine*  
2 x 100 W  
*attacco*  
B15D

*vetro*  
cristallo trasparente  
*metallo*  
ferro verniciato  
a polvere antracite  
*diffusore*  
cristallo satinato

**floor lamp**

*dimensions*  
h. 61.02"  
Ø 16.54"  
*weight*  
20 kg.

*light bulbs*  
2 x 100 W  
*socket*  
B15D

*glass*  
transparent crystal  
*metal type*  
anthracite powder  
coated iron  
*shade*  
glazed crystal

**p. 32**



**efra**  
1984

mito

**efra/2**

lampada da tavolo

*dimensioni*  
h. 290 mm  
Ø 200 mm  
*peso*  
2,50 kg.

*lampadine*  
60 W incandescenza  
42 W ecolamp  
*attacco*  
E27

*vetro*  
cristallo trasparente  
*metallo*  
ferro verniciato  
a polvere antracite /  
ottone naturale  
*diffusore*  
cristallo satinato

**table lamp**

*dimensions*  
h. 11.42"  
Ø 7.87"  
*weight*  
2,50 kg.

*light bulbs*  
60 W incandescent lamp  
42 W ecolamp  
*socket*  
E27

*glass*  
transparent crystal  
*metal type*  
anthracite powder  
coated iron /  
natural brass  
*shade*  
glazed crystal

**p. 20**



**faro**  
2003

maree

**o74.LG**

lampada da tavolo

*dimensioni*  
h. 790 mm  
Ø 480 mm  
*peso*  
4,80 kg.

*lampadine*  
60 W incandescenza  
42 W ecolamp  
*attacco*  
E27  
dimmerabile

*vetro*  
base: cristallo trasparente  
stelo: cristallo  
con spirale lattimo / grigio  
*metallo*  
cromo lucido  
*diffusore*  
tessuto

**table lamp**

*dimensions*  
h. 31.10"  
Ø 18.90"  
*weight*  
4,80 kg.

*light bulbs*  
60 W incandescent lamp  
42 W ecolamp  
*socket*  
E27 - dimmable

*glass*  
base: transparent crystal  
stem: crystal with white /  
grey spiral  
*metal type*  
polished chrome  
*shade*  
fabric

**p. 74**



**faro**  
2003

maree

**o74.RN**

lampada da tavolo

*dimensioni*  
h. 790 mm  
Ø 480 mm  
*peso*  
4,80 kg.

*lampadine*  
60 W incandescenza  
42 W ecolamp  
*attacco*  
E27  
dimmerabile

*vetro*  
base: cristallo trasparente  
stelo: cristallo  
con spirale nera / corallo  
*metallo*  
cromo lucido  
*diffusore*  
tessuto

**table lamp**

*dimensions*  
h. 31.10"  
Ø 18.90"  
*weight*  
4,80 kg.

*light bulbs*  
60 W incandescent lamp  
42 W ecolamp  
*socket*  
E27 - dimmable

*glass*  
base: transparent crystal  
stem: crystal with black /  
coral red spiral  
*metal type*  
polished chrome  
*shade*  
fabric

**p. 74**



**igra**  
1984

mito

**igra**

lampada da tavolo

*dimensioni*  
h. 370 mm  
Ø 390 mm  
*peso*  
11 kg.

*lampadine*  
60 W incandescenza  
42 W ecolamp  
*attacco*  
E27

*vetro*  
cristallo trasparente  
*metallo*  
ferro verniciato  
a polvere antracite /  
ottone naturale  
*diffusore*  
bianco latte

**table lamp**

*dimensions*  
h. 14.57"  
Ø 15.35"  
*weight*  
11 kg.

*light bulbs*  
60 W incandescent lamp  
42 W ecolamp  
*socket*  
E27

*glass*  
transparent crystal  
*metal type*  
anthracite powder  
coated iron / natural brass  
*shade*  
white

**p. 28**



**led.nastrino**  
2012

lumina

**led.nastrino**

lampada da tavolo

*dimensioni*  
h. 265 mm  
Ø 130 mm  
*peso*  
1,90 kg.

*lampadine*  
2,4 W  
*attacco*  
led

*vetro*  
cristallo trasparente  
*metallo*  
sorgente led  
in cromo lucido  
*diffusore*  
n. d.

**table lamp**

*dimensions*  
h. 10.43"  
Ø 5.12"  
*weight*  
1,90 kg.

*light bulbs*  
2,4 W  
*socket*  
led

*glass*  
transparent crystal  
*metal type*  
polished chrome  
led light source  
*shade*  
n. d.

**p. 84**



**led.polari**  
2012

lumina

**led.polari**

lampada da tavolo

*dimensioni*  
h. 270 mm  
Ø 102 mm  
*peso*  
2,30 kg.

*lampadine*  
2,4 W  
*attacco*  
led

*vetro*  
cristallo trasparente  
con spirale rossa / cristallo  
*metallo*  
sorgente led  
in cromo lucido  
*diffusore*  
n. d.

**table lamp**

*dimensions*  
h. 10.63"  
Ø 4.02"  
*weight*  
2,30 kg.

*light bulbs*  
2,4 W  
*socket*  
led

*glass*  
transparent crystal  
with red / crystal spiral  
*metal type*  
polished chrome  
led light source  
*shade*  
n. d.

**p. 80**



**medusa**  
1996

dune

**o50.A**

lampada da tavolo

*dimensioni*  
h. 508 mm  
Ø 260 mm  
*peso*  
1,80 kg.

*lampadine*  
40 W incandescenza  
28 W ecolamp  
*attacco*  
E14

*vetro*  
base e stelo:  
cristallo trasparente  
*diffusore*: cristallo satinato  
con spirale blu/verde  
*metallo*  
cromo sabbiato  
*diffusore*  
cristallo satinato  
con spirale blu/verde

**table lamp**

*dimensions*  
h. 20"  
Ø 10.24"  
*weight*  
1,80 kg.

*light bulbs*  
40 W incandescent lamp  
28 W ecolamp  
*socket*  
E14

*glass*  
base and stem:  
transparent crystal  
*shade*:  
glazed crystal  
with blue/green spiral  
*metal type*  
sanded chrome  
*shade*  
glazed crystal  
with blue/green spiral

**p. 54**





**medusa**  
1996

dune

**050.B**

lampada da tavolo

*dimensioni*  
h. 508 mm  
Ø 260 mm  
*peso*  
1,80 kg.

*lampadine*  
40 W incandescenza  
28 W ecolamp  
*attacco*  
E 14

*vetro*  
base e stelo:  
cristallo trasparente  
*diffusore*: cristallo satinato  
con spirale rosso/nero  
*metallo*  
cromo sabbiato  
*diffusore*  
cristallo satinato  
con spirale rosso/nero

table lamp

*dimensions*  
h. 20"  
Ø 10.24"  
*weight*  
1,80 kg.

*light bulbs*  
40 W incandescent lamp  
28 W ecolamp  
*socket*  
E14

*glass*  
base and stem:  
transparent crystal  
*shade*:  
glazed crystal  
with red/black spiral  
*metal type*  
sanded chrome  
*shade*  
glazed crystal  
with red/black spiral

**p. 54**



**office**  
1994

isole

**L.197.E**

lampada da tavolo

*dimensioni*  
h. 380 mm  
Ø 400 mm  
*peso*  
2,70 kg.

*lampadine*  
2 x 40 W incandescenza  
2 x 28 W ecolamp  
*attacco*  
E 14

*vetro*  
bianco latte  
*metallo*  
cromo lucido  
*diffusore*  
bianco latte

table lamp

*dimensions*  
h. 14.96"  
Ø 15.75"  
*weight*  
2,70 kg.

*light bulbs*  
2 x 40 W incandescent lamp  
2 x 28 W ecolamp  
*socket*  
E14

*glass*  
white  
*metal type*  
polished chrome  
*shade*  
white

**p. 46**



**ovale**  
1994

isole

**95.OPC**

lampada da tavolo

*dimensioni*  
h. 690 mm  
Ø 480 mm  
*peso*  
8,50 kg.

*lampadine*  
60 W incandescenza  
42 W ecolamp  
*attacco*  
E 27

*vetro*  
nero  
*metallo*  
cromo lucido  
*diffusore*  
bianco latte

table lamp

*dimensions*  
h. 27.17"  
Ø 18.90"  
*weight*  
8,50 kg.

*light bulbs*  
60 W incandescent lamp  
42 W ecolamp  
*socket*  
E27

*glass*  
black  
*metal type*  
polished chrome  
*shade*  
white

**p. 68**



**ovale**  
1994

isole

**95.OPD**

lampada da tavolo

*dimensioni*  
h. 690 mm  
Ø 480 mm  
*peso*  
8,50 kg.

*lampadine*  
60 W incandescenza  
42 W ecolamp  
*attacco*  
E 27

*vetro*  
cristallo trasparente  
*metallo*  
metallo dorato  
*diffusore*  
bianco latte

table lamp

*dimensions*  
h. 27.17"  
Ø 18.90"  
*weight*  
8,50 kg.

*light bulbs*  
60 W incandescent lamp  
42 W ecolamp  
*socket*  
E27

*glass*  
transparent crystal  
*metal type*  
golded metal  
*shade*  
white

**p. 68**



**quati**  
1984

mito

**quati**

lampada da tavolo

*dimensioni*  
h. 400 mm  
Ø 190 mm  
*peso*  
3,20 kg.

*lampadine*  
60 W incandescenza  
42 W ecolamp  
*attacco*  
E14

*vetro*  
cristallo trasparente  
*metallo*  
ferro verniciato a polvere  
antracite / ottone naturale  
*diffusore*  
bianco latte

table lamp

*dimensions*  
h. 15.75"  
Ø 7.48"  
*weight*  
3,20 kg.

*light bulbs*  
60 W incandescent lamp  
42 W ecolamp  
*socket*  
E14

*glass*  
transparent crystal  
*metal type*  
anthracite powder coated  
iron / natural brass  
*shade*  
white

**p. 24**



**scudo**  
2002

isole

**scudo**

lampada da tavolo

*dimensioni*  
h. 520 mm  
Ø 440 mm  
*peso*  
3,60 kg.

*lampadine*  
75 W  
*attacco*  
halopin G9

*vetro*  
cristallo/cristallo satinato  
*metallo*  
cromo lucido  
*diffusore*  
cristallo/cristallo satinato

table lamp

*dimensions*  
h. 20.47"  
Ø 17.32"  
*weight*  
3,60 kg.

*light bulbs*  
75 W  
*socket*  
halopin G9

*glass*  
crystal/glazed crystal  
*metal type*  
polished chrome  
*shade*  
crystal/glazed crystal

**p. 64**



**snodo**  
1978

isole

**002.81**

lampada da tavolo

*dimensioni*  
h. 500 mm  
Ø 395 mm  
*peso*  
5,90 kg.

*lampadine*  
2 x 60 W incandescenza  
2 x 42 W ecolamp  
*attacco*  
E27

*vetro*  
bianco latte  
*metallo*  
cromo lucido  
*diffusore*  
bianco latte

table lamp

*dimensions*  
h. 19.69"  
Ø 15.55"  
*weight*  
5,90 kg.

*light bulbs*  
2 x 60 W incandescent lamp  
2 x 42 W ecolamp  
*socket*  
E27

*glass*  
white  
*metal type*  
polished chrome  
*shade*  
white

**p. 60**



**truba**  
1984

mito

**truba**

lampada da terra

*dimensioni*  
h. 2200 mm  
Ø 180 mm  
*peso*  
9 kg.

*lampadine*  
150 W  
*attacco*  
B15D  
dimmerabile

*vetro*  
cristallo trasparente  
*metallo*  
ferro verniciato  
a polvere antracite  
*diffusore*  
bianco latte

floor lamp

*dimensions*  
h. 86.61"  
Ø 7.09"  
*weight*  
9 kg.

*light bulbs*  
150 W  
*socket*  
B15D

*glass*  
transparent crystal  
*metal type*  
anthracite powder  
coated iron  
*shade*  
white

**p. 36**





**boblu**  
2015

contract project

**801.100.A**

lampada a sospensione

*dimensioni*  
h. 100 mm  
Ø 100 mm  
*peso*  
0,30 kg.

*lampadine*  
led 3 W

*vetro*  
cristallo trasparente / lattimo  
*metallo*  
alluminio anodizzato

suspension lamp

*dimensions*  
h. 3.94"  
Ø 3.94"  
*weight*  
0,30 kg.

*light bulbs*  
led 3 W

*glass*  
transparent crystal / white  
*metal type*  
anodized aluminum

p. 98



**boblu**  
2015

contract project

**801.140.A**

lampada a sospensione

*dimensioni*  
h. 140 mm  
Ø 140 mm  
*peso*  
0,60 kg.

*lampadine*  
led 3 W

*vetro*  
cristallo trasparente / lattimo  
*metallo*  
alluminio anodizzato

suspension lamp

*dimensions*  
h. 5.51"  
Ø 5.51"  
*weight*  
0,60 kg.

*light bulbs*  
led 3 W

*glass*  
transparent crystal / white  
*metal type*  
anodized aluminum

p. 98



**boblu**  
2015

contract project

**801.180.A**

lampada a sospensione

*dimensioni*  
h. 180 mm  
Ø 180 mm  
*peso*  
1,50 kg.

*lampadine*  
led 3 W

*vetro*  
cristallo trasparente / lattimo  
*metallo*  
alluminio anodizzato

suspension lamp

*dimensions*  
h. 7.09"  
Ø 7.09"  
*weight*  
1,50 kg.

*light bulbs*  
led 3 W

*glass*  
transparent crystal / white  
*metal type*  
anodized aluminum

p. 98



**boblu**  
2015

contract project

**801.100.B**

lampada a sospensione

*dimensioni*  
h. 100 mm  
Ø 100 mm  
*peso*  
0,30 kg.

*lampadine*  
led 3 W

*vetro*  
cristallo trasparente /  
cannette grigio e lattimo  
*metallo*  
alluminio anodizzato

suspension lamp

*dimensions*  
h. 3.94"  
Ø 3.94"  
*weight*  
0,30 kg.

*light bulbs*  
led 3 W

*glass*  
transparent crystal /  
little grey and white rods  
*metal type*  
anodized aluminum

p. 98





**boblu**  
2015

contract project

**801.140.B**

lampada a sospensione

*dimensioni*  
h. 140 mm  
Ø 140 mm  
*peso*  
0,60 kg.

*lampadine*  
led 3 W

*vetro*  
cristallo trasparente /  
cannette grigio e lattimo  
*metallo*  
alluminio anodizzato

suspension lamp

*dimensions*  
h. 5.51"  
Ø 5.51"  
*weight*  
0,60 kg.

*light bulbs*  
led 3 W

*glass*  
transparent crystal /  
little grey and white rods  
*metal type*  
anodized aluminum

p. 98



**boblu**  
2015

contract project

**801.180.B**

lampada a sospensione

*dimensioni*  
h. 180 mm  
Ø 180 mm  
*peso*  
1,50 kg.

*lampadine*  
led 3 W

*vetro*  
cristallo trasparente /  
cannette grigio e lattimo  
*metallo*  
alluminio anodizzato

suspension lamp

*dimensions*  
h. 7.09"  
Ø 7.09"  
*weight*  
1,50 kg.

*light bulbs*  
led 3 W

*glass*  
transparent crystal /  
little grey and white rods  
*metal type*  
anodized aluminum

p. 98



**boblu**  
2015

contract project

**801.100.C**

lampada a sospensione

*dimensioni*  
h. 100 mm  
Ø 100 mm  
*peso*  
0,30 kg.

*lampadine*  
led 3 W

*vetro*  
cristallo trasparente / lattimo /  
cannette grigio in pasta /  
fascia nera  
*metallo*  
alluminio anodizzato

suspension lamp

*dimensions*  
h. 3.94"  
Ø 3.94"  
*weight*  
0,30 kg.

*light bulbs*  
led 3 W

*glass*  
transparent crystal / white /  
little grey rods / black band  
*metal type*  
anodized aluminum

p. 98



**boblu**  
2015

contract project

**801.140.C**

lampada a sospensione

*dimensioni*  
h. 140 mm  
Ø 140 mm  
*peso*  
0,60 kg.

*lampadine*  
led 3 W

*vetro*  
cristallo trasparente / lattimo /  
cannette grigio in pasta /  
fascia nera  
*metallo*  
alluminio anodizzato

suspension lamp

*dimensions*  
h. 5.51"  
Ø 5.51"  
*weight*  
0,60 kg.

*light bulbs*  
led 3 W

*glass*  
transparent crystal / white /  
little grey rods / black band  
*metal type*  
anodized aluminum

p. 98



**boblu**  
2015

contract project

**801.180.C**

lampada a sospensione

*dimensioni*  
h. 180 mm  
Ø 180 mm  
*peso*  
1,50 kg.

*lampadine*  
led 3 W

*vetro*  
cristallo trasparente / lattimo /  
cannette grigio in pasta /  
fascia nera  
*metallo*  
alluminio anodizzato

suspension lamp

*dimensions*  
h. 7.09"  
Ø 7.09"  
*weight*  
1,50 kg.

*light bulbs*  
led 3 W

*glass*  
transparent crystal / white /  
little grey rods / black band  
*metal type*  
anodized aluminum

p. 98



**boblu**  
2015

contract project

**801.100.D**

lampada a sospensione

*dimensioni*  
h. 100 mm  
Ø 100 mm  
*peso*  
0,30 kg.

*lampadine*  
led 3 W

*vetro*  
acciaio trasparente /  
decorazione rigadin ottico  
*metallo*  
alluminio anodizzato

suspension lamp

*dimensions*  
h. 3.94"  
Ø 3.94"  
*weight*  
0,30 kg.

*light bulbs*  
led 3 W

*glass*  
transparent steel / "rigadin"  
optical ornament  
*metal type*  
anodized aluminum

p. 98



**boblu**  
2015

contract project

**801.140.D**

lampada a sospensione

*dimensioni*  
h. 140 mm  
Ø 140 mm  
*peso*  
0,60 kg.

*lampadine*  
led 3 W

*vetro*  
acciaio trasparente /  
decorazione rigadin ottico  
*metallo*  
alluminio anodizzato

suspension lamp

*dimensions*  
h. 5.51"  
Ø 5.51"  
*weight*  
0,60 kg.

*light bulbs*  
led 3 W

*glass*  
transparent steel / "rigadin"  
optical ornament  
*metal type*  
anodized aluminum

p. 98



**boblu**  
2015

contract project

**801.180.D**

lampada a sospensione

*dimensioni*  
h. 180 mm  
Ø 180 mm  
*peso*  
1,50 kg.

*lampadine*  
led 3 W

*vetro*  
acciaio trasparente /  
decorazione rigadin ottico  
*metallo*  
alluminio anodizzato

suspension lamp

*dimensions*  
h. 7.09"  
Ø 7.09"  
*weight*  
1,50 kg.

*light bulbs*  
led 3 W

*glass*  
transparent steel / "rigadin"  
optical ornament  
*metal type*  
anodized aluminum

p. 98





**boblu**  
2015

contract project

**801.100.E**

lampada a sospensione

*dimensioni*  
h. 100 mm  
Ø 100 mm  
*peso*  
0,30 kg.

*lampadine*  
led 3 W

*vetro*  
cristallo trasparente con  
finitura in foglia oro / lattimo  
*metallo*  
alluminio anodizzato

suspension lamp

*dimensions*  
h. 3.94"  
Ø 3.94"  
*weight*  
0,30 kg.

*light bulbs*  
led 3 W

*glass*  
transparent crystal with gold  
leaf finishing / white  
*metal type*  
anodized aluminum

p. 98



**boblu**  
2015

contract project

**801.140.E**

lampada a sospensione

*dimensioni*  
h. 140 mm  
Ø 140 mm  
*peso*  
0,60 kg.

*lampadine*  
led 3 W

*vetro*  
cristallo trasparente con  
finitura in foglia oro / lattimo  
*metallo*  
alluminio anodizzato

suspension lamp

*dimensions*  
h. 5.51"  
Ø 5.51"  
*weight*  
0,60 kg.

*light bulbs*  
led 3 W

*glass*  
transparent crystal with gold  
leaf finishing / white  
*metal type*  
anodized aluminum

p. 98



**boblu**  
2015

contract project

**801.180.E**

lampada a sospensione

*dimensioni*  
h. 180 mm  
Ø 180 mm  
*peso*  
1,50 kg.

*lampadine*  
led 3 W

*vetro*  
cristallo trasparente con  
finitura in foglia oro / lattimo  
*metallo*  
alluminio anodizzato

suspension lamp

*dimensions*  
h. 7.09"  
Ø 7.09"  
*weight*  
1,50 kg.

*light bulbs*  
led 3 W

*glass*  
transparent crystal  
with gold leaf finishing / white  
*metal type*  
anodized aluminum

p. 98



**boblu S**  
2014

contract project

**801.810.F**

lampadario a soffitto

*dimensioni*  
h. 527 mm  
Ø 810 mm  
*peso*  
18 kg.

*lampadine*  
15 x 40 W  
2 x 3 W led (coppa)  
*attacco*  
G9

*vetro*  
lattimo con decoro rosso  
*metallo*  
cromo satinato

chandelier

*dimensions*  
h. 20.57"  
Ø 31.89"  
*weight*  
18 kg.

*light bulbs*  
15 x 40 W  
2 x 3 W led (final cup)  
*socket*  
G9

*glass*  
white with red ornament  
*metal type*  
glazed chrome

p. 102

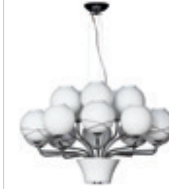

**boblu S**  
2014

contract project

**801.810.G**

lampadario a soffitto

*dimensioni*  
h. 527 mm  
Ø 810 mm  
*peso*  
18 kg.

*lampadine*  
15 x 40 W  
2 x 3 W led (coppa)  
*attacco*  
G9

*vetro*  
lattimo con decoro  
grigio in pasta  
*metallo*  
cromo satinato

chandelier

*dimensions*  
h. 20.57"  
Ø 31.89"  
*weight*  
18 kg.

*light bulbs*  
15 x 40 W  
2 x 3 W led (final cup)  
*socket*  
G9

*glass*  
white with grey ornament  
*metal type*  
glazed chrome

p. 102

I Cristalli Carlo Moretti sono realizzati singolarmente a mano con processo di preparazione della massa fluida eseguito secondo tecniche tradizionali atipiche. Questo artigianale ed esclusivo processo di produzione conferisce ai prodotti un valore unico, singolare ed irripetibile. Eventuali piccole imperfezioni, differenze nella sfumatura dei colori, presenza di bollicine o altre apparenti imperfezioni, varianti di dimensione e peso sono da considerarsi caratteristica distintiva e di pregio della lavorazione manuale. Ogni singolo oggetto è firmato a mano a punta diamante, alcuni sono in edizioni limitate e numerate per anno accompagnate da relativo certificato di autenticità.

**Carlo Moretti Crystals are made individually by hand with the preparation process of the fluid mass following atypical traditional techniques.**

**It is this artisan and exclusive production process that gives the products their unique, characteristic and unrepeatable value. Any small imperfections, differences in the shades of the colours, the presence of bubbles or other apparent imperfections, variations in size or weight, are to be considered a distinctive characteristic and a merit of being produced by hand. Each object is hand-signed with a diamond point, some are produced in a limited edition, numbered by year and accompanied by an authenticity certificate.**



**B**  
Boblu p. 98  
Boblu S p. 102  
Bricola p. 76

**C**  
Cilla p. 42  
Cupola p. 50

**D**  
Drima p. 32

**E**  
Efra p. 20

**F**  
Faro p. 74

**I**  
Igra p. 28

**L**  
Led. Nastrino p. 84  
Led. Polari p. 80

**M**  
Medusa p. 54

**O**  
Office p. 46  
Ovale p. 68

**Q**  
Quati p. 24

**S**  
Scudo p. 64  
Snodo p. 60

**T**  
Truba p. 36

**002.81** Snodo  
lampada da tavolo p. 60

**050.A** Medusa  
lampada da tavolo p. 54

**050.B** Medusa  
lampada da tavolo p. 54

**072.A** Bricola  
lampada da tavolo p. 76

**072.B** Bricola  
lampada da tavolo p. 76

**072.LG** Bricola  
lampada da tavolo p. 76

**074.LG** Faro  
lampada da tavolo p. 74

**074.RN** Faro  
lampada da tavolo p. 74

**093.o** Cilla  
lampada da tavolo p. 42

**094.o** Cilla  
lampada da tavolo p. 42

**094/G** Cilla lampada  
lampada da tavolo p. 42

**801.100.A** Boblu  
sfera sospensione p. 98

**801.100.B** Boblu  
sfera sospensione p. 98

**801.100.C** Boblu  
sfera sospensione p. 98

**801.100.D** Boblu  
sfera sospensione p. 98

**801.100.E** Boblu  
sfera sospensione p. 98

**801.140.A** Boblu  
sfera sospensione p. 98

**801.140.B** Boblu  
sfera sospensione p. 98

**801.140.C** Boblu  
sfera sospensione p. 98

**801.140.D** Boblu  
sfera sospensione p. 98

**801.140.E** Boblu  
sfera sospensione p. 98

**801.180.A** Boblu  
sfera sospensione p. 98

**801.180.B** Boblu  
sfera sospensione p. 98

**801.180.C** Boblu  
sfera sospensione p. 98

**801.180.D** Boblu  
sfera sospensione p. 98

**801.180.E** Boblu  
sfera sospensione p. 98

**801.810.F** Boblu S  
lampadario p. 102

**801.810.G** Boblu S  
lampadario p. 102

**95.OPC** Ovale  
lampada da tavolo p. 68

**95.OPD** Ovale  
lampada da tavolo p. 68

**Drima** Drima  
lampada da terra p. 32

**Efra/2** Efra  
lampada da tavolo p. 20

**Igra** Igra  
lampada da tavolo p. 28

**L.092.E** Cupola  
lampada da tavolo p. 50

**L.197.E** Office  
lampada da tavolo p. 46

**L.292.E** Cupola  
lampada da tavolo p. 50

**Led.Nastrino** Led.Nastrino  
lampada da tavolo p. 84

**Led.Polari** Led.Polari  
lampada da tavolo p. 80

**Quati** Quati  
lampada da tavolo p. 24

**Scudo** Scudo  
lampada da tavolo p. 64

**Truba** Truba  
lampada da terra p. 36

Riconoscimenti  
**Awards**

Medaglia d'oro  
Internationalen  
Handwerksmesse  
München 1966

Premio Internationales  
Kunsth Handwerk  
Stuttgart 1966

Premio Macef 1976

Arango International  
Design Competition  
Glass That Works Miami  
Fi, USA 1984

Selezione Compasso  
d'oro 1987 calici  
cavo cono

Selezione Compasso  
d'oro 1989 calici  
ovale piede ovale

Selezione Compasso  
d'oro 1991 calici soffio

Trophée:prix decouvertés  
Maison et Objet  
Settembre 1997 per calici  
da Collezione 1998

Musei dove sono conservati  
oggetti di Carlo Moretti  
**Museums exhibiting  
Carlo Moretti glass**

**Germania**  
**Germany**

Staatliche Museum  
Preussischer Kulturbesitz  
Kunstgewerbemuseum in Berlin

Badisches  
Landesmuseum  
Karlsruhe in Karlsruhe

Europäische Abteilung  
Museum für Kunsthandwerk  
in Frankfurt am Main

Staatliche Kunstsammlungen  
Dresden Kunstgewerbemuseum  
in Dresden

Kunstmuseum Düsseldorf  
im Ehrenhof in Düsseldorf

Kunstsammlungen der  
Veste Coburg in Coburg

**Svizzera**  
**Switzerland**

Musée Ariana in Genève

**Finlandia**  
**Finland**

National Board of Antiquities  
in Helsinki

The Finnish Glass  
Museum in Riihimäki

**Repubblica Ceca**  
**Czech Republic**

Museum of Decorative Arts  
in Prague

**Gran Bretagna**  
**Great Britain**

Victoria and Albert  
Museum in London

The Cecil Higgins Art  
Gallery in Bedford

**Italia**  
**Italy**

Museo del Vetro in Murano  
Venezia

**Francia**  
**France**

Glass Collection of the Regional  
Council in Rouen Cedex

Musée des Arts  
Décoratifs in Paris

**Stati Uniti**  
**United States**

Cooper-Hewitt Museum  
in New York

The Corning Museum of Glass  
in Corning New York

The Museum of Modern Art  
in New York

Museum of Contemporary Art  
in Chicago

Philadelphia Museum of Art  
in Philadelphia

**Israele**  
**Israel**

The Israel Museum in Jerusalem

**Portogallo**  
**Portugal**

Museo do Design c/o  
Centro Culturale di Belém Lisboa

**Belgio**  
**Belgium**

Musée du Verre Charleroi

Mostre dedicate alle opere  
di Carlo Moretti  
**Exhibitions dedicated  
to Carlo Moretti glass**

Verre & Verres  
Parigi 1995  
Galerie Différences

Carlo Moretti  
1958/1992  
Un segno del nostro tempo  
Treviso 1992  
Casa dei Carraresi Cassamarca

Carlo Moretti  
1958/1988  
Un segno del nostro tempo  
Milano 1988  
Museo della Scienza e della tecnica  
Leonardo da Vinci

Mostre in cui sono state presenti  
le opere di Carlo Moretti  
**Exhibitions including  
Carlo Moretti glass**

Abitare il Tempo  
Verona  
1991/1992/1993/1994

Cento vetri.  
Opere in vetro  
Dal 1951 al 1987  
Venezia 1987  
Fondazione Scientifica  
Querini Stampalia

Venezia Aperto Vetro  
Venezia 1996/1998  
Palazzo Ducale



Carlo Moretti SpA  
Fondamenta Manin 3  
30141 Murano  
Venezia - Italia  
+39 041 736 588  
info@carlomoretti.com

hand - Made in Italy - murano  
carlomoretti.com

*catalogue by*  
Carlo Moretti communication team

*art direction, editorial concept  
and graphic design*  
tapiro

*photocredits*  
Francesco Barasciutti  
Ettore Bellini  
Andrea Piovesan

*p. 108 drawing*  
Diego Chilò

*translations*  
Christina Cawthra

*technical illustration*  
Giorgio Renzi  
Marco Scapin

*made and printed in Italy*  
aprile 2015

*edition*  
© Carlo Moretti S.p.A. aprile 2015

Diritti di proprietà industriale e intellettuale  
I modelli, i nomi commerciali, i marchi, nomi a dominio,  
le fotografie ed i testi presenti in questo sito/catalogo  
sono di esclusiva proprietà di Carlo Moretti S.p.A. e  
protetti secondo le norme a tutela dei diritti di Proprietà  
Industriale ed intellettuale. Qualsiasi loro riproduzione  
anche parziale, modificazione, pubblicazione o altra  
forma di utilizzo, se non espressamente autorizzata da  
Carlo Moretti S.p.A., è vietata.

Industrial and Intellectual Property rights  
All the designs, brands, trademarks, domain names,  
the pictures and contents of this web site/catalogue  
are exclusively owned by Carlo Moretti S.p.A. and  
are protected by the relevant provisions of Industrial  
and Intellectual Property Law. Their unauthorized  
reproduction even partial, modification, publication and  
any other use are strictly prohibited.







Carlo Moretti