

STEPHANE PARMENTIER  
×  
GIOBAGNARA

COMPLETE CATALOGUE

SEPTEMBER 2023



## GIOBAGNARA AND STÉPHANE PARMENTIER

Stéphane Parmentier first met Giorgio Bagnara a few years ago in the aisles of a professional trade show. Enamored of the beauty and the quality of the leathers used, not to mention the meticulous attention to detail evident in each piece, he regularly contacted GIOBAGNARA to realize the custom-made home furnishings in leather or suede that he designed for private clients.

Very soon, the two built a rapport based on a shared sense of rigor, a quest for excellence down to the smallest detail and a taste for modern elegance expressed through sleek design, beautiful materials — and a mutual taste for audacity.

In 2017, their animated creative dialogue and a shared ambition to bring a new perspective to the market naturally led Giorgio Bagnara to entrust Stéphane Parmentier with the artistic direction of GIOBAGNARA. Since the beginning of this collaboration, Stéphane Parmentier has designed a wide number of new creations for the brand, from boxes, cases, desktop objects, storage units, change trays, trays, candle holders and vases to furniture and leather — or suede — trimmed lamps in a wide array of colours.

In blending tradition, aesthetic heritage and modernity, Stéphane Parmentier brings a graphic and sensual sensibility to a typically Italian art of living of which he is particularly fond.



### GIORGIO BAGNARA, FOUNDER AND CEO OF GIOBAGNARA

Born into a family renowned for cultivating for three generations the art of living, Giorgio Bagnara became passionate about his calling at a very early age. In the late Nineties, after noticing that leather from the fashion industry was not considered enough as material for home accessories, he founded GIOBAGNARA with the goal of applying it to a complete collection. Along with his wife, Vanessa, he first moves his design studios and workshops in the old docks of the Port of Genoa and, later, in a renowned historical building near Genoa's Marina where, surrounded by the essence and beauty of that location, the company took a significant step forward.

### GIOBAGNARA

A brand that is distinctive for elegantly designed creations that express luxury without ostentation, available in an uncommon and virtually limitless colour palette of leathers and suede, and crafted to the highest standards using both traditional know-how and leading-edge technology.

This approach to tradition and modernity led Giorgio Bagnara to experiment: he constantly pushes technical limits in his quest for objects that are both beautiful and relevant, and in doing so relies on the skills of the company's craftspeople. Very quickly, GIOBAGNARA became renowned for its expertise, and its founder became a partner of choice for a large number of interior decorators and yacht and jet designers who called upon his know-how for special commissions. In 2015, Giorgio Bagnara expanded its leather portfolio with the acquisition of the saddle leather specialist Rabitti 1969. Today, nearly two decades after its founding, GIOBAGNARA has one of the most comprehensive offers of leather home accessories on the market and is preparing to open a fresh chapter in its history.



### STÉPHANE PARMENTIER CREATIVE DIRECTOR OF GIOBAGNARA

The interior architect and designer Stéphane Parmentier began his career working for Karl Lagerfeld before deciding to devote himself to architecture full-time in 2002. Since then, he has created and developed numerous projects for an international clientele attuned to his style of luxurious simplicity. The homes and objects he designs reveal a vision that is deeply anchored in a modern everyday lifestyle. Inspired by classical Greco-Roman antiquity, the beauty of the Puglian landscape, the restraint of the Japanese aesthetic, and a desire to focus on the essential, he cultivates elegant asceticism by associating noble materials with subtly graphic lines.

TABOU  
SCULPTURE

A mix of space-age design and tribal art, these contemporary totems are great decorative pieces able to create a connection between abstraction and figuration.

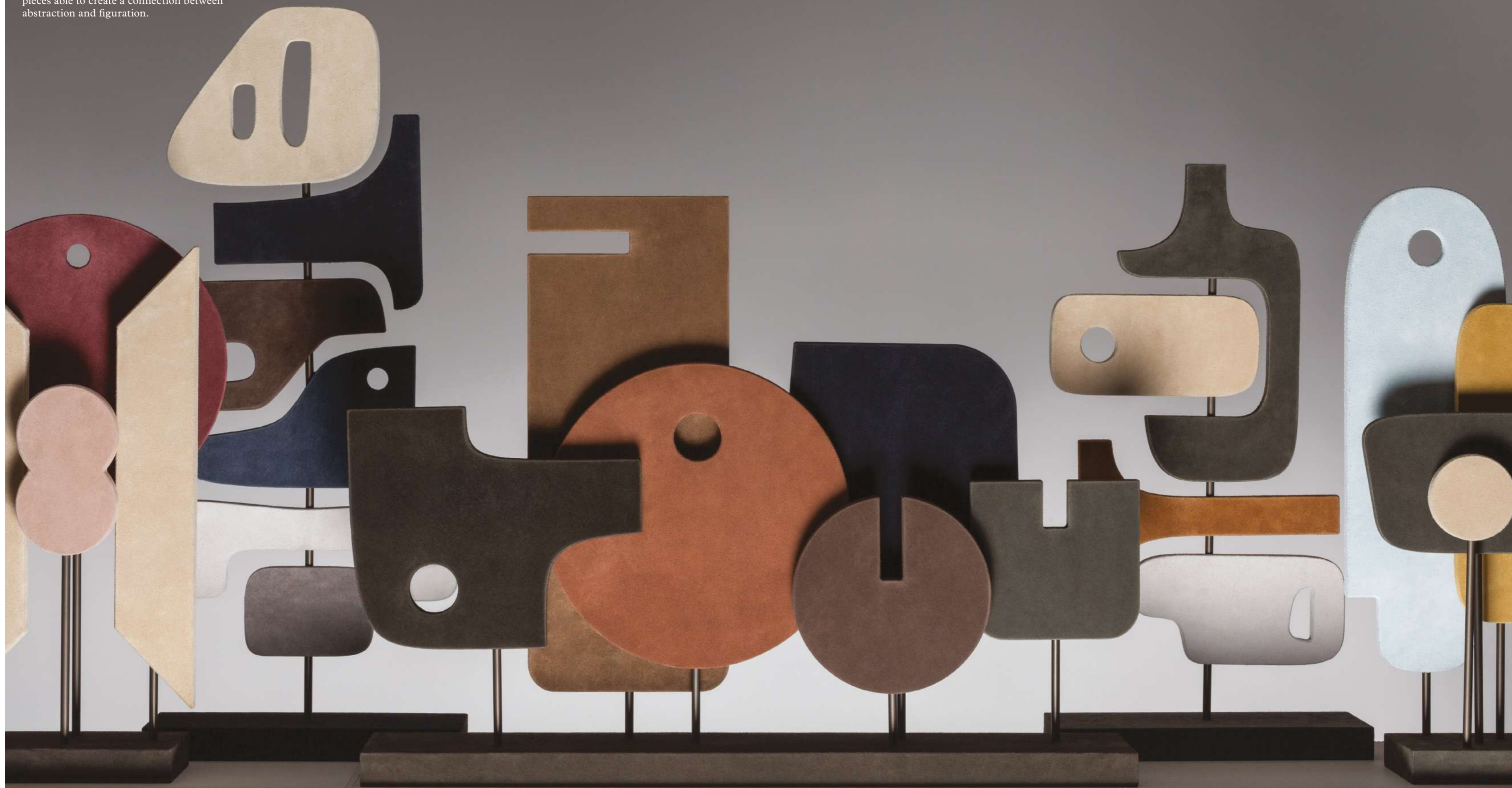

TABOU  
SCULPTURE  
1



HAP081  
cm 21.5 x 15.5 | h. cm 55

Suede-covered wood shapes and bronze sticks.

TABOU  
SCULPTURE  
2



HAP082  
cm 27.5 x 15 | h. cm 51.5

Suede-covered wood shapes and bronze sticks.

TABOU  
SCULPTURE  
3



HAP083  
cm 30 x 15.5 | h. cm 72

Suede-covered wood shapes and bronze sticks.

TABOU  
SCULPTURE  
4



HAP084  
cm 30 x 15 | h. cm 57.5

Suede-covered wood shapes and bronze sticks.

TABOU  
SCULPTURE  
5



HAP085  
cm 72 x 18 | h. cm 54

Suede-covered wood shapes and bronze sticks.



TABOU  
MARBLE  
SCULPTURES

The Tabou collection's statement pieces are now declined in their all-travertine version, featuring a selection of elegant nuances.

A mix of space-age design and tribal art, these contemporary totems are great decorative pieces able to create a connection between abstraction and figuration.



TABOU  
MARBLE  
SCULPTURE  
1



HAP081M  
cm 21.5 x 15.5 | h. cm 55

Marble shapes in 5 varieties of travertine and bronze sticks.

TABOU  
MARBLE  
SCULPTURE  
2



HAP082M  
cm 27.5 x 15 | h. cm 51.5

Marble shapes in 4 varieties of travertine and bronze sticks.

TABOU  
MARBLE  
SCULPTURE  
5



HAP085M  
cm 72 x 18 | h. cm 54

Marble shapes in 6 varieties of travertine  
and bronze sticks.

## SAN MARCO SCULPTURE

The San Marco sculpture is the result of a mix of space-age design and tribal art, this sculpture is able to create a connection between abstraction and figuration, and features an interplay of contrasting yet complimentary shades and textures due to the use of delicate, soft suede together with the sophisticated, naturally charming Osso travertine. Such juxtaposition enhances shapes and volumes, giving birth to an inimitable collectible piece with a timeless beauty.

HAP086  
cm 37.5 x 17 | h cm 66.5

Available only in suede and Osso travertine.

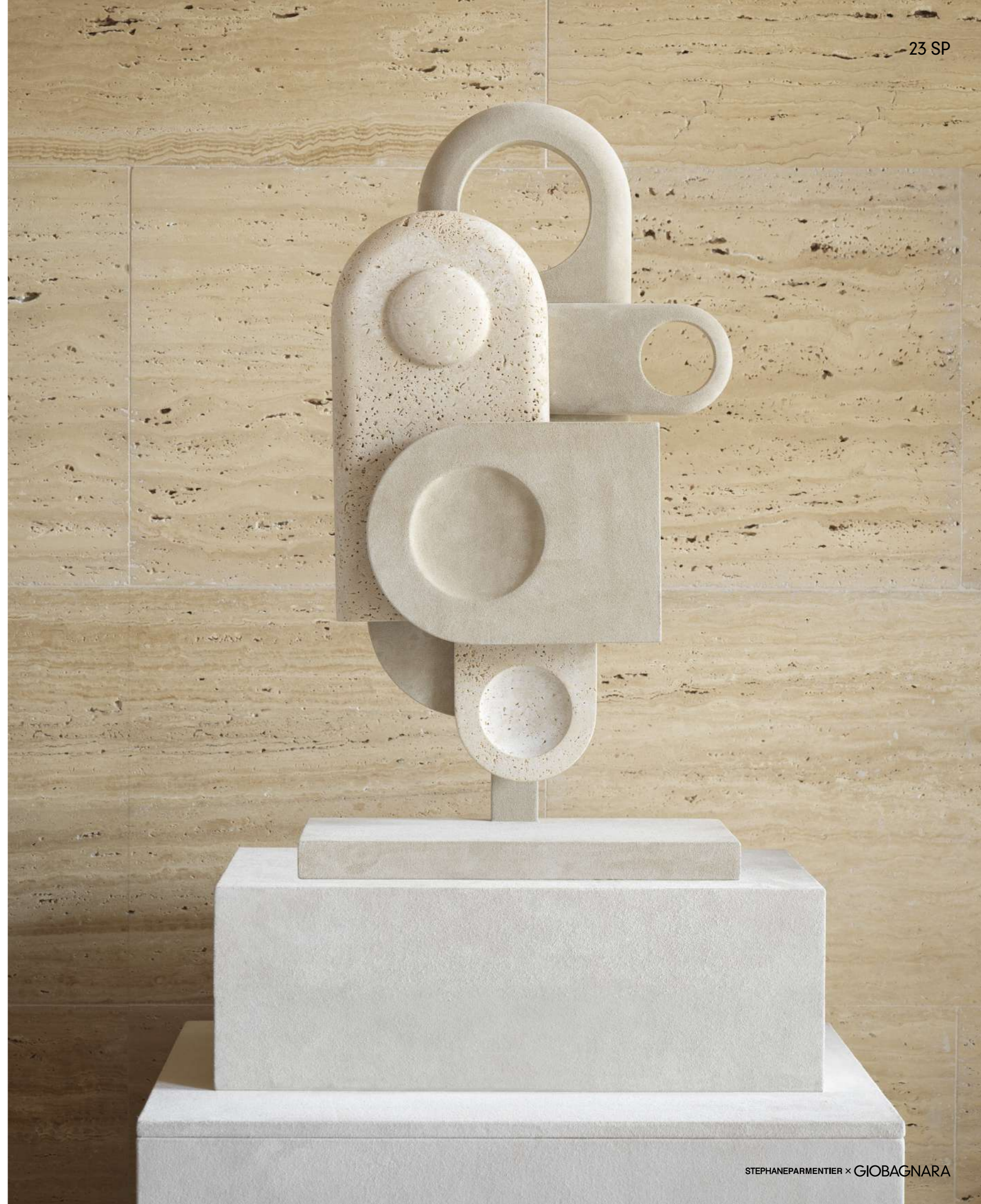

## TABOU PARETE

Almost like three-dimensional paintings, these artworks are great decorative pieces able to create a connection between abstraction and figuration, mixing space-age design and tribal art. The fluid forms are covered in suede, introducing a novel material in the field of wall decorations.

## TABOU PARETE 1



HAP071  
*cm 31 x 61 x 11*

Suede-covered wood shapes.

TABOU  
PARETE  
2



HAP072  
cm 40.5 x 59 x 4.5

Suede-covered wood shapes.

TABOU  
PARETE  
3

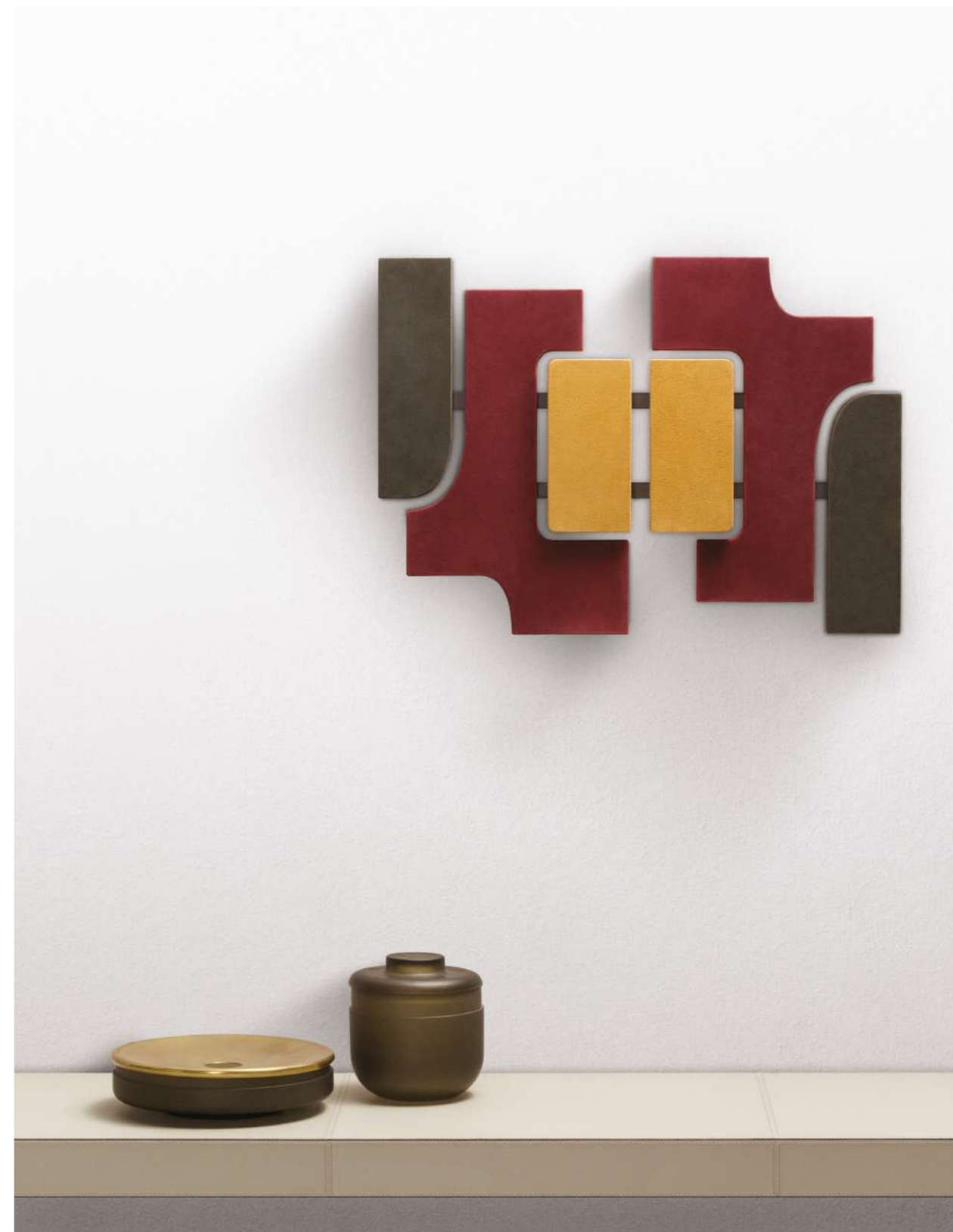

HAP073  
cm 59 x 42.5 x 4

Suede-covered wood shapes  
and bronze inserts.

TABOU  
PARETE  
4



HAP074  
cm 50 x 82 x 4

Suede-covered wood shapes  
and bronze inserts.

TABOU  
PARETE  
5

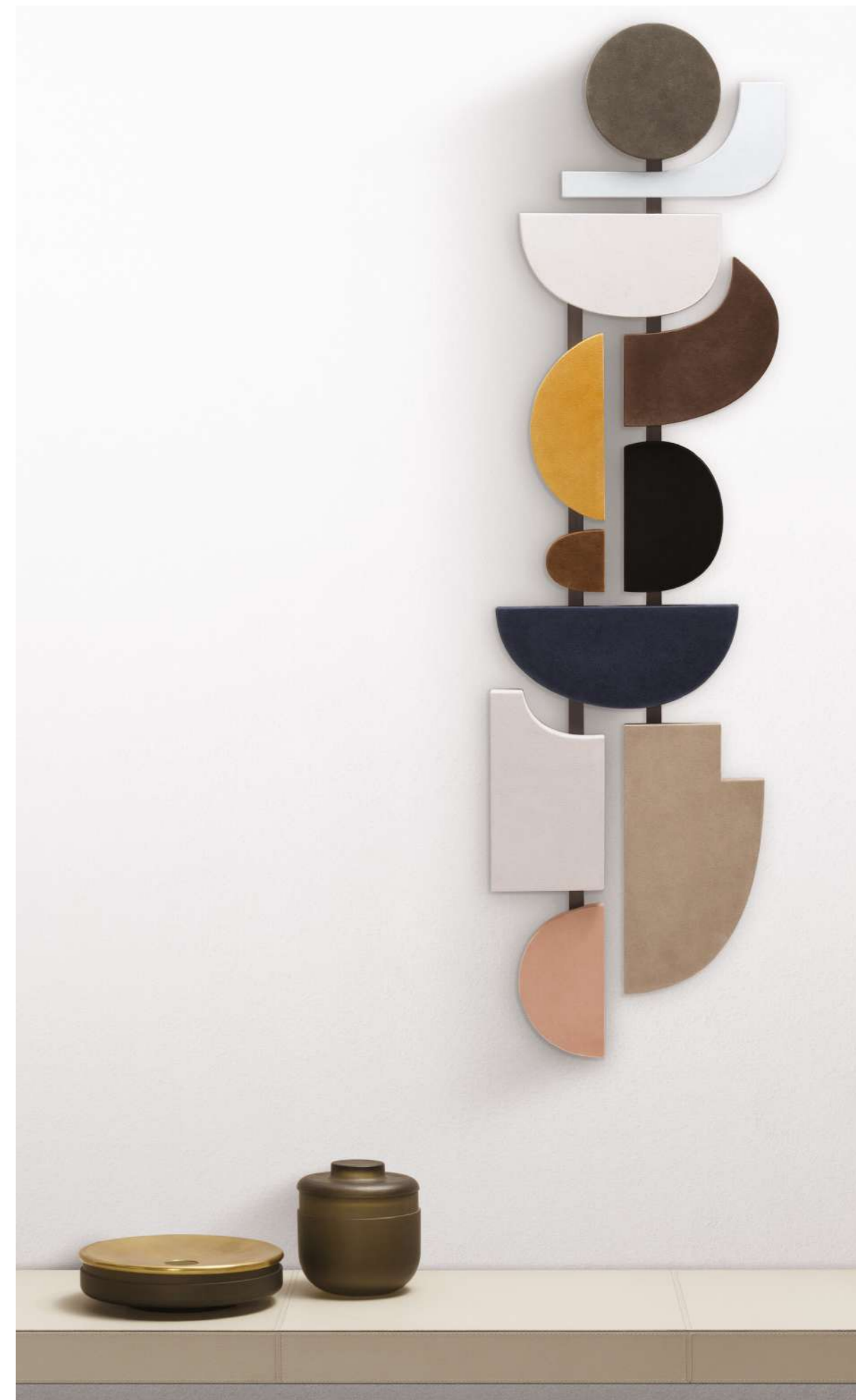

HAP075  
cm 36 x 131 x 4

Suede-covered wood shapes  
and bronze inserts

**TABOU  
SOLID**

Hung on a wall like paintings or used as decorative elements on a shelf, these three-dimensional units covered in suede, used individually or in multiple compositions, create a connection between the minimalist sculptures by Donald Judd and the graphic geometries of Ettore Sottsass.

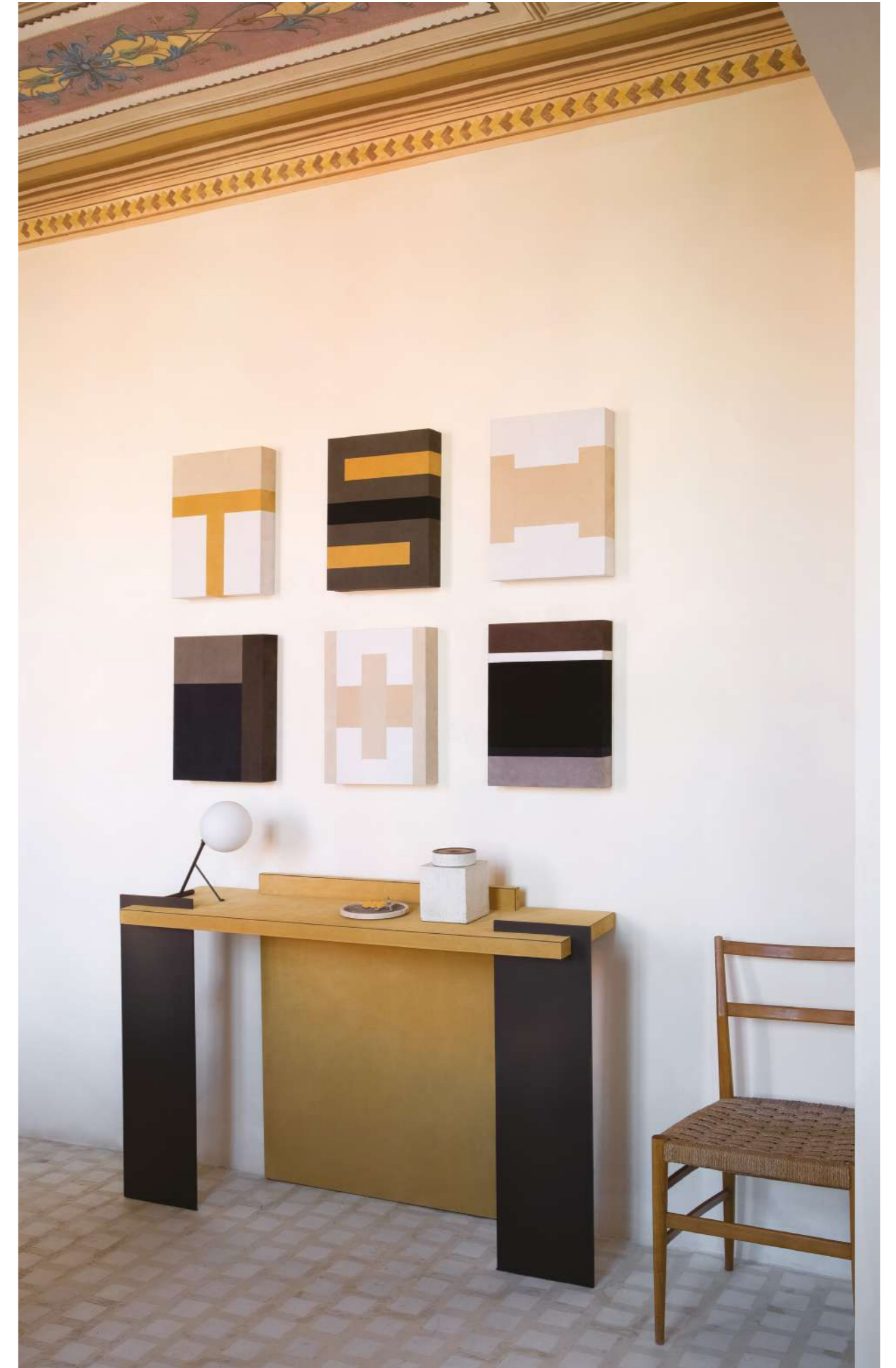





1



2



3



4



5



6



7

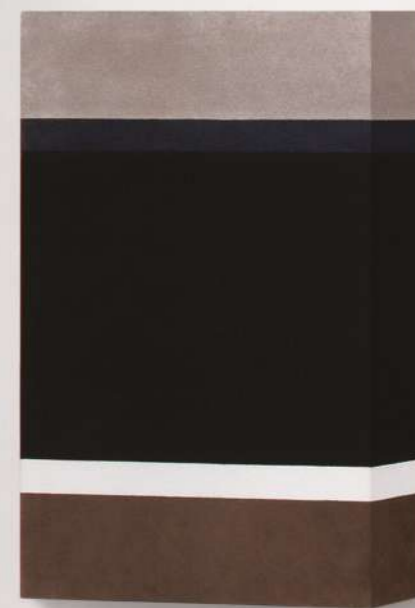

8

Tabou Solid 1 — HAP101  
cm 32.5 x 44.5 x 8

Tabou Solid 2 — HAP102  
cm 32.5 x 44.5 x 8

Tabou Solid 5 — HAP105  
cm 32.5 x 44.5 x 8

Tabou Solid 6 — HAP106  
cm 32.5 x 44.5 x 8

Suede-covered wood structure.

Tabou Solid 3 — HAP103  
cm 32.5 x 44.5 x 8

Tabou Solid 4 — HAP104  
cm 32.5 x 44.5 x 8

Tabou Solid 7 — HAP107  
cm 32.5 x 44.5 x 8

Tabou Solid 8 — HAP108  
cm 32.5 x 44.5 x 8

Suede-covered wood structure.

## TABOU CORNICE

These suede-covered wood structure wall sculptures are framed in black or white nappa.  
The interaction between colours and shapes makes them decorative pieces based on pure geometry, where abstraction and figuration create formal structures that allow colour to dominate.

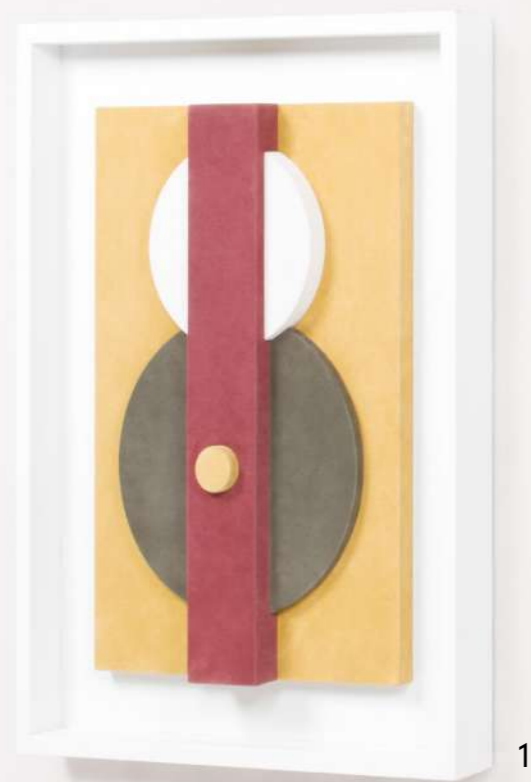

TABOU  
CORNICE

1

Tabou Cornice 1 — HAP121  
cm 46.5 x 61.5 x 7

Tabou Cornice 2 — HAP122  
cm 46.5 x 61.5 x 6

Tabou Cornice 3 — HAP123  
cm 46.5 x 61.5 x 6.5

leather: suede + black or white nappa frame



2



3

TABOU  
CORNICE

4



5

Tabou Cornice 4 — HAP124  
cm 46.5 x 61.5 x 6

Tabou Cornice 5 — HAP125  
cm 46.5 x 61.5 x 6

Tabou Cornice 6 — HAP126  
cm 46.5 x 61.5 x 6

leather: suede + black or white nappa frame



6

TABOU  
CORNICE  
GIANT

This leather-covered wood structure wall sculpture is framed in white suede.  
The interaction between colours and shapes makes it a decorative piece based on pure geometry, where abstraction and figuration create formal structures that allow colour to dominate.  
The fluid forms are covered in suede on a black nappa background.



HAP100  
cm 96.5 x 136 x 7.5  
leather: suede + nappa



TABOU  
ORIZZONTE

These nappa-covered wood structure artworks framed in black or white suede are minimalist decorative pieces of pure geometry. Their compositions of formal structures, which allow colour to dominate, are references to the works of Joseph Albers and Donald Judd.

Central lines always in black + white nappa.

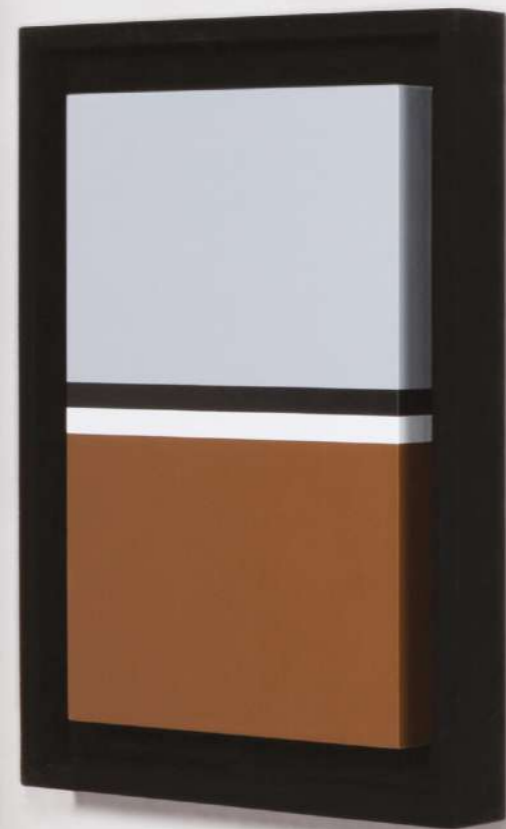

HAP130  
cm 45.5 x 60.5 x 6



## PARAGGI TABLE LAMPS

The architectural silhouette of Ligurian lighthouses is translated by Stéphane Parmentier into sculptural table lamps composed of a leather-covered wood base and a lampshade in cotton fabric.



small — LTP015  
Ø cm 19.5 | h. cm 29.5

medium — LTP016  
Ø cm 25.5 | h. cm 37

large — LTP017  
Ø cm 31.5 | h. cm 45

E27 light bulb max. 100W not included.



EOLIE  
TABLE  
LAMPS

Eolie is a collection where the meticulous perfection of handmade weaving meets the flawless, elegant simplicity of pure forms and proportions.

The woven rattan, with its warm natural nuances, boasts captivating light and dark effects and conveys a feeling of weightlessness, while the combination with an ideally heavy metal base brings forth a subtle interplay of contrasting yet complimentary textures.







round — LFP013  
Ø cm 27 | h. cm 41

material: woven rattan  
metal: bronze



square — LFP014  
cm 25 x 25 | h. cm 41

material: woven rattan  
metal: bronze



LIPARI  
TABLE  
LAMPS

Lipari is a collection that aims to find harmony between opposites: the natural, delicate texture of the woven rattan shade on each lamp reveals a beautiful, soothing glow when lit, while the geometrical rigor of the sturdy metal base creates captivating strong contrasts, boasting an exceptional magnetic charm.

Metal finishes available:  
chrome / bronze / brass.



chrome   bronze   brass

small — LTP021  
cm 31.5 x 20 | h. cm 36  
light bulb E27 100 W

medium — LTP022  
cm 43 x 29 | h. cm 50  
light bulb E27 100 W

large — LTP023  
cm 51.5 x 35 | h. cm 60  
light bulb E27 100 W

base: aluminium  
lampshade: woven rattan







## DUOMO TABLE LAMPS

Boasting distinctive features that make this collection stand out, Duomo combines references to the lighting trends of the 1970s with clean, minimal lines and geometrical volumes, as well as unique materials, resulting in a sculptural luminous appearance.

Featuring iconic curved bronze lampshades and plinths, these lamps sit upon bases covered with woven rattan, which provides the pieces with a lighter, informal feeling.

These lamps cast a soft ambient light that's ideal for reading and lounging.

small — LTP026  
Ø cm 23 | h. cm 18  
light bulb E27 100 W

medium — LTP027  
Ø cm 32 | h. cm 30  
light bulb E27 100 W

large — LTP028  
Ø cm 48 | h. cm 44  
light bulb E27 100 W

Lampshade and base: bronze  
Body: woven rattan  
Voltage available: 110V or 220V.









## ORION CHANDELIER

Featuring an essential conic shape, the massive volume of the Orion chandelier is rendered weightless by the use of the finest, meticulously handwoven rattan.

Hanging from sturdy chains made with burnished brushed bronze, this piece boasts captivating contrasts of materials, weights, shades and textures.

Custom sizes available on request.

LCP005

*main structure: Ø cm 120 | h cm 44  
suspensions' length adjustable on request.*

Woven rattan with burnished brushed bronze suspension chains.



## ORION APPLIQUE

Featuring a minimal sinuous shape, the Orion applique is rendered weightless by the use of the finest, meticulously handwoven rattan combined with a smooth, shiny leather border and boasts captivating contrasts of materials, weights, shades and textures.

Custom sizes available on request.



LWP005

cm 33.5 x 10 | h cm 36

Woven rattan structure with nappa leather border.  
Only available as showcased in the images.



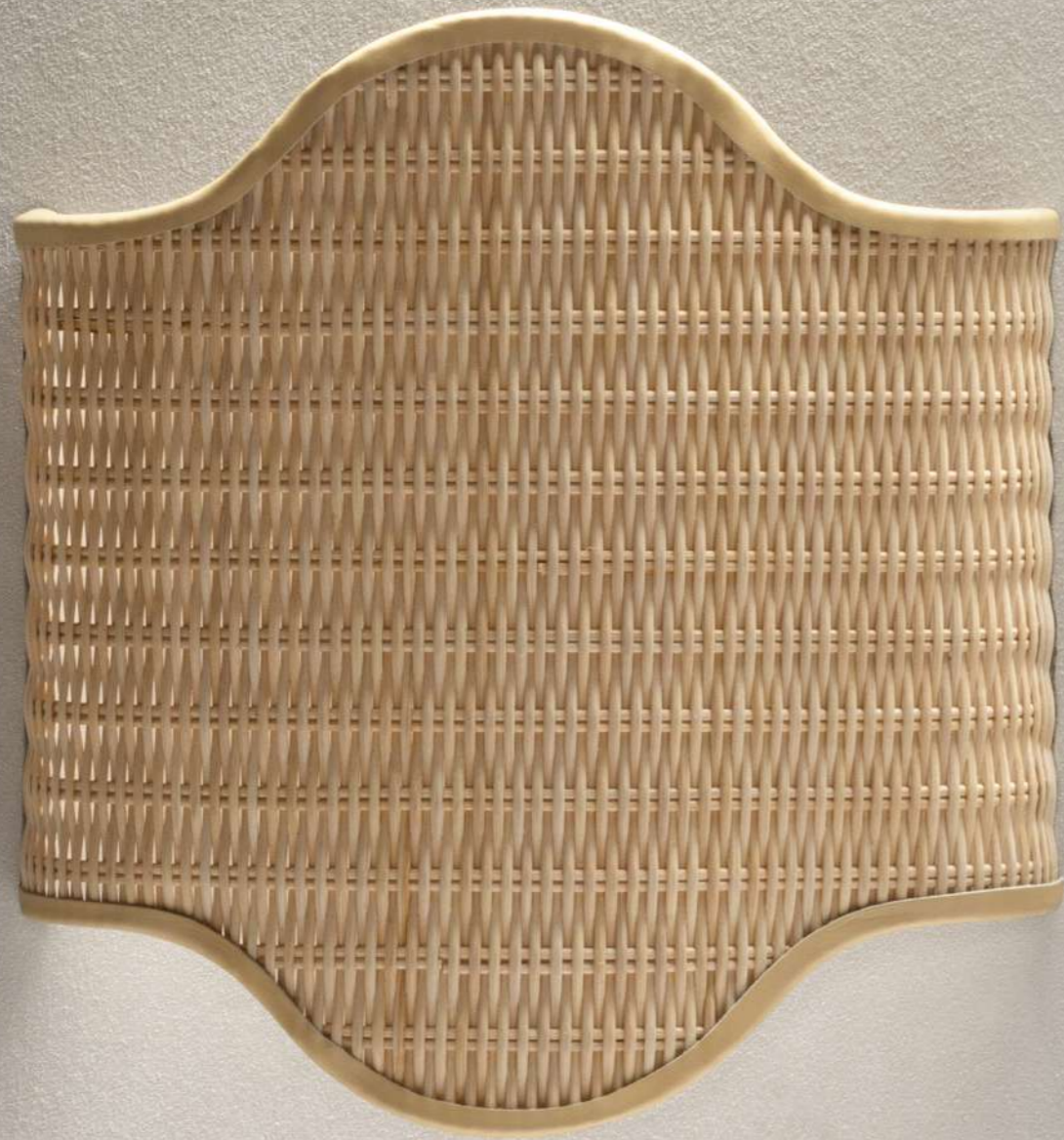

## PALAZZO

Created as a graphic homage to the architecture and stylized ornamentation of Italian palazzos, the Palazzo line combines travertine (an emblematic stone in Italy) with nappa leather and suede. Lamps, candleholders, vases, trays and change trays with detachable bases subtly underscore contrasts of texture, colour and material.



PALAZZO  
TABLE  
LAMP

small — LTP115  
Ø cm 27 | h. cm 41.5

medium — LTP116  
Ø cm 36 | h. cm 59

large — LTP117  
Ø cm 44 | h. cm 72

leathers: suede



PALAZZO  
CANDLE  
HOLDER



single — HAP050  
cm 16 x 16 | h. cm 33

triple — HAP060  
cm 48 x 16 | h. cm 33

leathers: golf, suede, nappa

PALAZZO  
VASE



HAP070  
*cm 16 x 16 | h. cm 32.5*

leathers: printed calfskin, suede, nappa



PALAZZO  
TRAY /  
VALET TRAY

valet tray — TVP023  
cm 30 x 30 | h. cm 3  
removable leather pad

long rectangular — TVP860  
cm 80 x 30 | h. cm 3  
removable leather pad

square — TVP840  
cm 40 x 53.5 | h. cm 3  
removable leather pad

leathers: printed calfskin, suede, nappa





PALAZZO  
EIGHT  
VALET TRAY



TVP850  
cm 40 x 23.5 | h. cm 4  
removable leather pad

leathers: printed calfskin, suede, nappa

shearling — TVP852  
cm 40 x 23.5 | h. cm 4  
removable leather pad

leather: shearling





## GARIBALDI TRAY

This set of four trays in marquetry of nappa leather and suede presents a reinterpretation of various decorative elements and the motto "Venturi non immemor aevi" (=looking to the future without forgetting the past) emblazoned on the façade of the Bagnara family palazzo at Via Garibaldi 12 in Genoa. An architecturally informed vocabulary manifests itself with all the force of timeless elegance.

mini — TVP401  
cm 20 x 20 | h. cm 1.5

small — TVP402  
cm 26 x 26 | h. cm 1.5

medium — TVP403  
cm 32 x 32 | h. cm 1.5

large — TVP404  
cm 38 x 38 | h. cm 1.5

leathers: nappa + suede combination



## DAZZLE TRAY

These four nesting trays in marquetry of nappa leather and suede play on the graphics of diagonal two-toned lines and stripes. A nod to geometric abstraction and minimalism in an elegant and whimsical composition.

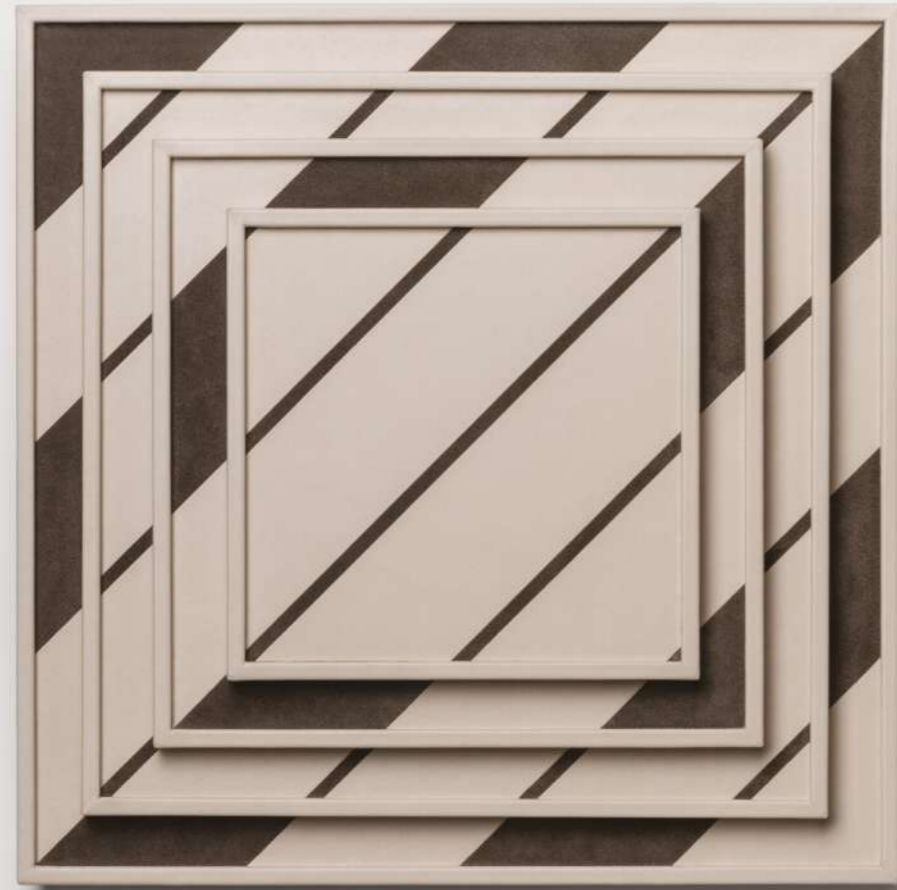

mini — TVP601  
cm 20 x 20 | h. cm 1.5

small — TVP602  
cm 26 x 26 | h. cm 1.5

medium — TVP603  
cm 32 x 32 | h. cm 1.5

large — TVP604  
cm 38 x 38 | h. cm 1.5

leathers: nappa + suede combination

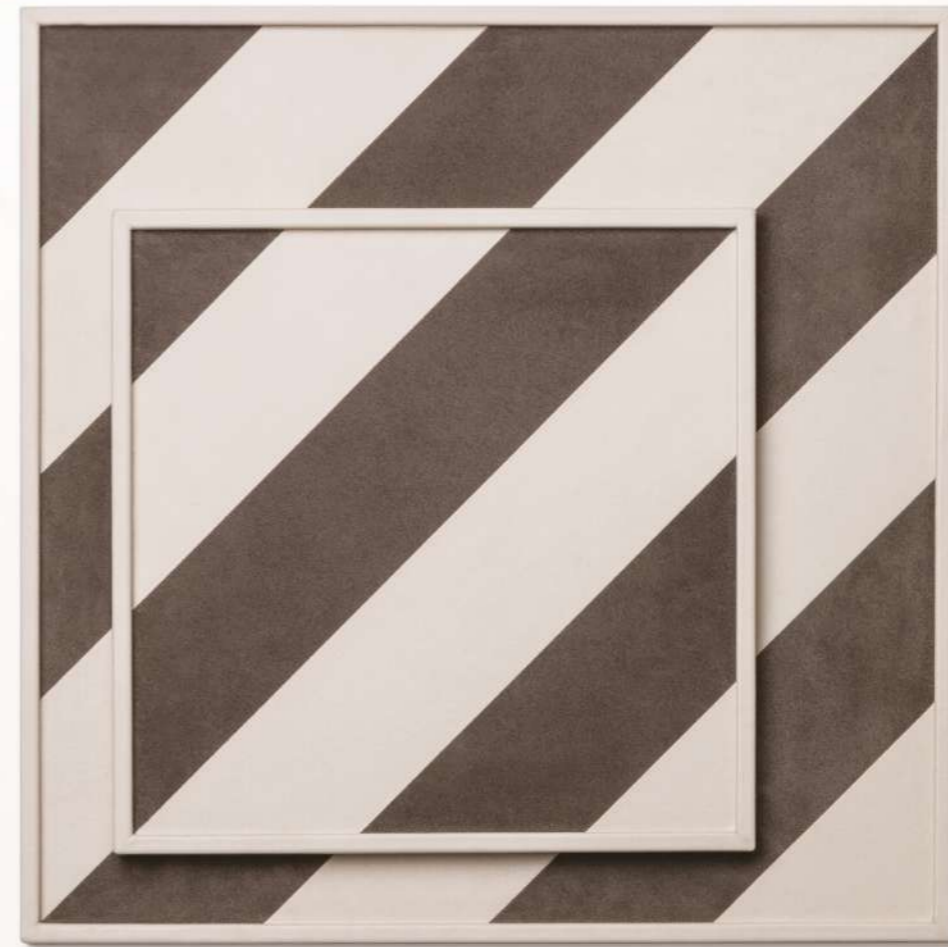

## AGORA BOWLS AND TRAY

A series of elegant presentation bowls and trays generously proportioned to be used as striking centrepieces. Also available with “Clouds” printed suede, they look like a tribute to the American artist Sterling Ruby.

small round bowl — HVP011  
Ø cm 20.5 | h. cm 8

medium round bowl — HVP012  
Ø cm 28.5 | h. cm 8

large round bowl — HVP013  
Ø cm 35.5 | h. cm 8

all leathers from our chart available





long oval tray — TVP011  
cm 51.5 x 20 | h. cm 8

all leathers from our chart available



BASEL  
VALET TRAY



mini — HVP001  
Ø cm 14.5 | h. cm 2

small — HVP002  
Ø cm 20 | h. cm 2

medium — HVP003  
Ø cm 25 | h. cm 2

large — HVP004  
Ø cm 29.5 | h. cm 2

leather: perforated suede  
metal: chrome, bronze, brass



## ENZO

A collection of valet trays and trays inspired by the Italian radical design of the 60s which nevertheless finds, in the combination of materials and colours, a new elegant or sporty spirit.





## ENZO RALLY

Enzo trays made of leather marquetry play on the graphics of two-toned lines and stripes. A hint of geometric abstraction and minimalism in an elegant and sporty composition.



small square valet tray — HVP201R  
*cm 20.5 x 20.5 | h. cm 3*

medium square valet tray — HVP202R  
*cm 24.5 x 24.5 | h. cm 3*

large square valet tray — HVP203R  
*cm 28.5 x 28.5 | h. cm 3*

small rectangular valet tray — HVP301R  
*cm 23.5 x 17.5 | h. cm 3*

medium rectangular valet tray — HVP302R  
*cm 27.5 x 20.5 | h. cm 3*

large rectangular valet tray — HVP303R  
*cm 31.5 x 23.5 | h. cm 3*

small long rectangular valet tray — HVP351R  
*cm 26.5 x 10 | h. cm 3*

medium long rectangular valet tray — HVP352R  
*cm 31.5 x 12 | h. cm 3*

large long rectangular valet tray — HVP353R  
*cm 35.5 x 14 | h. cm 3*

small square tray — TVP201R  
*cm 38 x 38 | h. cm 3*

large square tray — TVP203R  
*cm 48 x 48 | h. cm 3*

small rectangular tray — TVP301R  
*cm 38 x 28 | h. cm 3*

large rectangular tray — TVP303R  
*cm 48 x 38 | h. cm 3*

leathers: printed calfskin, suede, nappa



ENZO  
VALET TRAY  
RECTANGULAR



small rectangular valet tray — HVP301  
*cm 23.5 x 17.5 | h. cm 3*

medium rectangular valet tray — HVP302  
*cm 27.5 x 20.5 | h. cm 3*

large rectangular valet tray — HVP303  
*cm 31.5 x 23.5 | h. cm 3*

all leathers from our chart available

ENZO  
TRAY  
RECTANGULAR



small rectangular tray — TVP301  
*cm 38 x 28 | h. cm 3*

large rectangular tray — TVP303  
*cm 48 x 38 | h. cm 3*

all leathers from our chart available

ENZO  
VALET TRAY  
LONG RECTANGULAR

small long rectangular valet tray — HVP351  
*cm 26.5 x 10 | h. cm 3*

medium long rectangular valet tray — HVP352  
*cm 31.5 x 12 | h. cm 3*

large long rectangular valet tray — HVP353  
*cm 35.5 x 14 | h. cm 3*

all leathers from our chart available



ENZO  
VALET TRAY /  
TRAY  
SQUARE

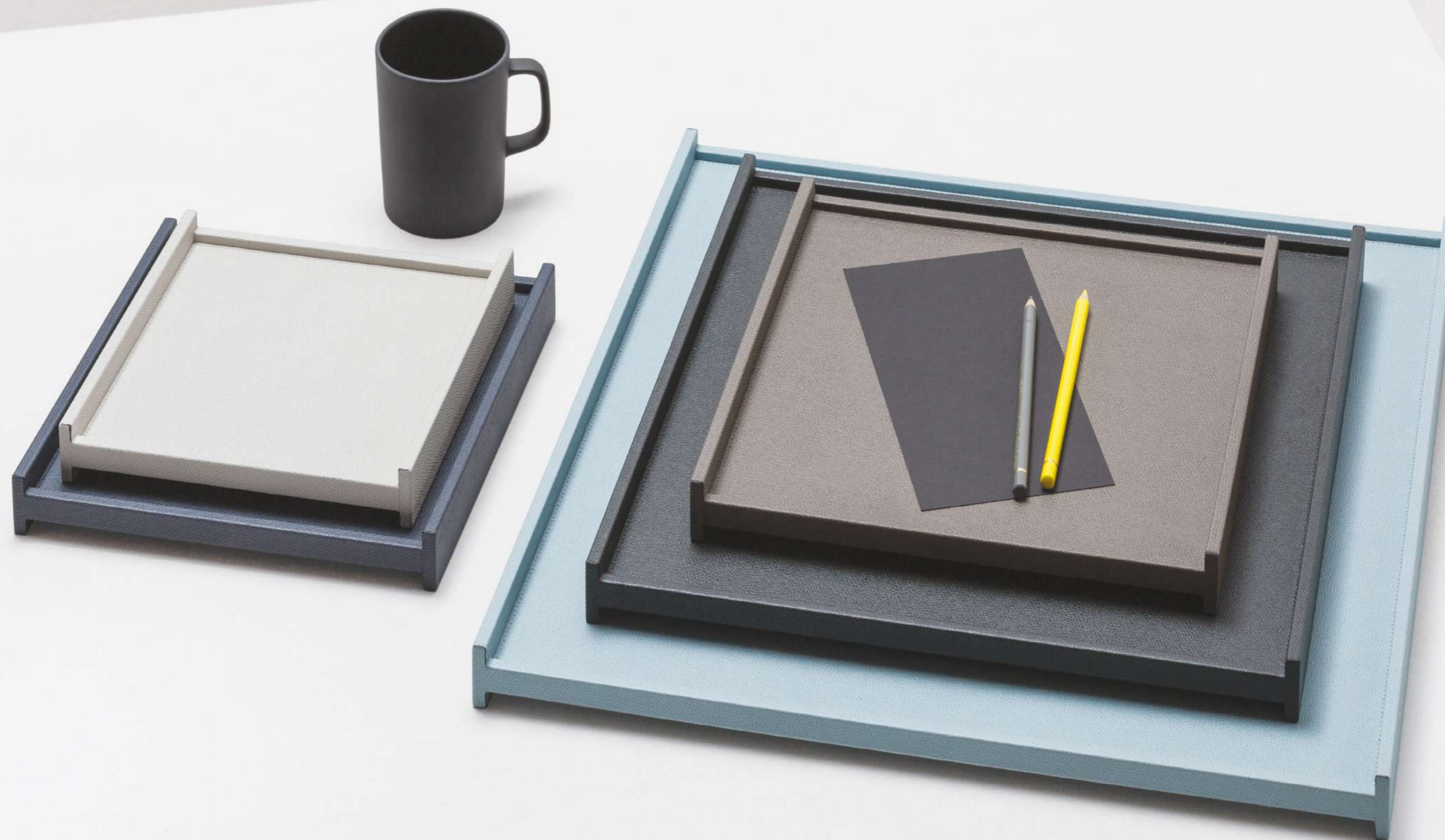

small square valet tray — HVP201  
*cm 20.5 x 20.5 | h. cm 3*

medium square valet tray — HVP202  
*cm 24.5 x 24.5 | h. cm 3*

large square valet tray — HVP203  
*cm 28.5 x 28.5 | h. cm 3*

small square tray — TVP201  
*cm 38 x 38 | h. cm 3*

large square tray — TVP203  
*cm 48 x 48 | h. cm 3*

all leathers from our chart available

## VITRUVIO VALET TRAYS

Vitruvio is a collection of suede valet trays available in a variety of sizes and shapes which takes inspiration from Classical architectural models and translates them in a graphic contemporary visual language.

Being characterized by minimal lines, forms range from rigorously geometric to smoothly curved.

Custom sizes available on request.



valet tray n°1 small — TVP121  
*cm 17 x 17 | h cm 1.5*

valet tray n°1 medium — TVP122  
*cm 26 x 26 | h cm 1.5*

valet tray n°1 large — TVP123  
*cm 35 x 35 | h cm 1.5*

Only available in suede.



valet tray n°2 small — TVP126  
*cm 17 x 18 | h cm 1.5*

valet tray n°2 medium — TVP127  
*cm 26 x 27 | h cm 1.5*

valet tray n°2 large — TVP128  
*cm 35 x 36.5 | h cm 1.5*

Only available in suede.



valet tray n°3 small — TVP131  
*cm 17 x 17 | h cm 1.5*

valet tray n°3 medium — TVP132  
*cm 26 x 26 | h cm 1.5*

valet tray n°3 large — TVP133  
*cm 35 x 35 | h cm 1.5*

Only available in suede.

## VITRUVIO MARBLE VALET TRAYS

Vitruvio is a collection of travertine valet trays available in a variety of sizes, shapes and colors, which takes inspiration from Classical architectural models and translates them in a graphic contemporary visual language. Being characterized by minimal lines, forms range from rigorously geometric to smoothly curved. Custom sizes available on request.

Travertine finishes available:

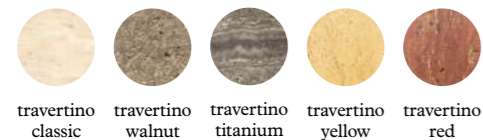

travertino classic   travertino walnut   travertino titanium   travertino yellow   travertino red



valet tray n°1 small — TVP121M  
cm 17 x 17 | h. cm 1.5

valet tray n°1 medium — TVP122M  
cm 26 x 26 | h. cm 1.5

valet tray n°1 large — TVP123M  
cm 35 x 35 | h. cm 1.5



valet tray n°2 small — TVP126M  
 cm 17 x 18 | h. cm 1.5

valet tray n°2 medium — TVP127M  
 cm 26 x 27 | h. cm 1.5

valet tray n°2 large — TVP128M  
 cm 35 x 36.5 | h. cm 1.5



valet tray n°3 small — TVP131M  
 cm 17 x 17 | h. cm 1.5

valet tray n°3 medium — TVP132M  
 cm 26 x 26 | h. cm 1.5

valet tray n°3 large — TVP133M  
 cm 35 x 35 | h. cm 1.5



## VITRUVIO PLINTHS

Vitruvio is a collection of suede plinths available in a variety of sizes and shapes which takes inspiration from Classical architectural models and translates them in a graphic contemporary visual language.

Being characterized by minimal lines, volumes range from rigorously geometric to smoothly curved and, by playing with combinations of heights and forms, it is possible to create virtually limitless display configurations.

Custom sizes available on request.



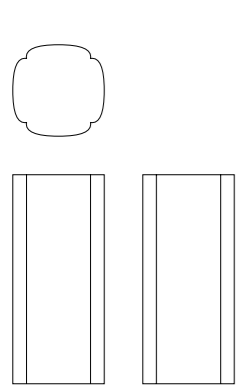

**VITRUVIO N°1  
SQUARE**

small low — HAP183  
cm 35 x 35 | h cm 80

Only available in suede.

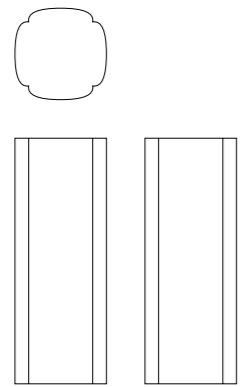

**VITRUVIO N°1  
SQUARE**

small high — HAP188  
cm 35 x 35 | h cm 94

Only available in suede.

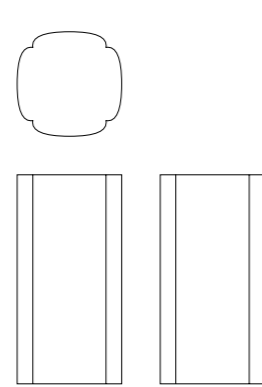

**VITRUVIO N°1  
SQUARE**

large low — HAP193  
cm 40 x 40 | h cm 80

Only available in suede.

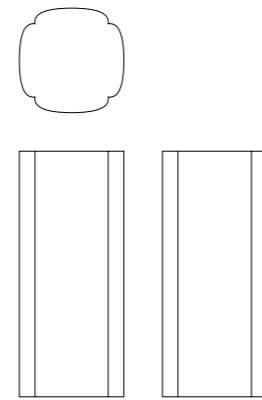

**VITRUVIO N°1  
SQUARE**

large high — HAP198  
cm 40 x 40 | h cm 94

Only available in suede.

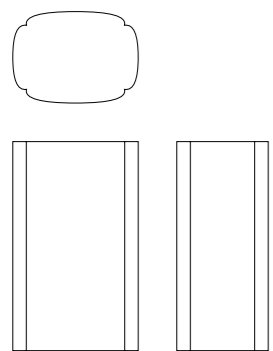

**VITRUVIO N°1  
RECTANGULAR**

small low — HAP203  
cm 48 x 35 | h cm 80

Only available in suede.

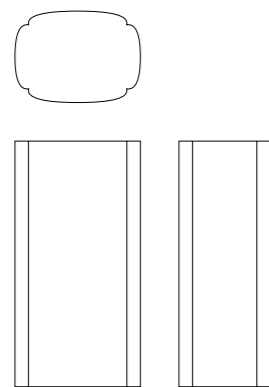

**VITRUVIO N°1  
RECTANGULAR**

small high — HAP208  
cm 48 x 35 | h cm 94

Only available in suede.

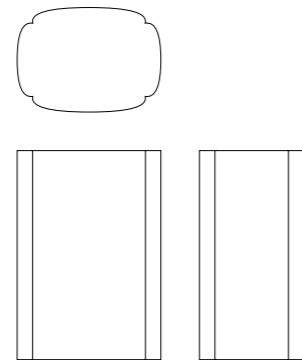

**VITRUVIO N°1  
RECTANGULAR**

large low — HAP213  
cm 55 x 40 | h cm 80

Only available in suede.

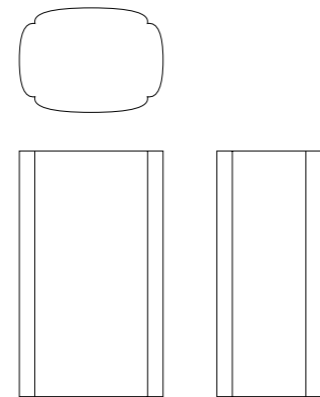

**VITRUVIO N°1  
RECTANGULAR**

large high — HAP218  
cm 55 x 40 | h cm 94

Only available in suede.

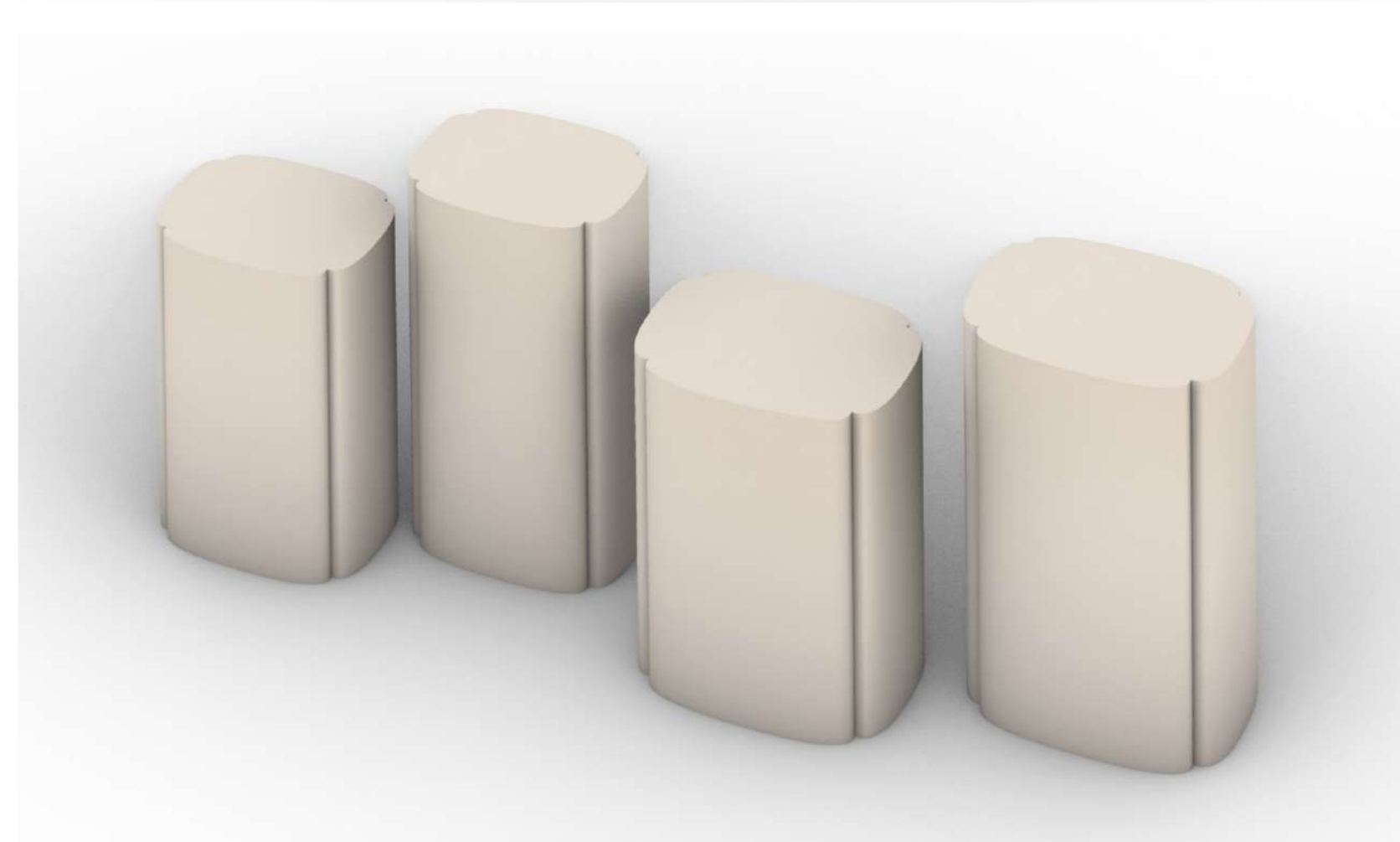
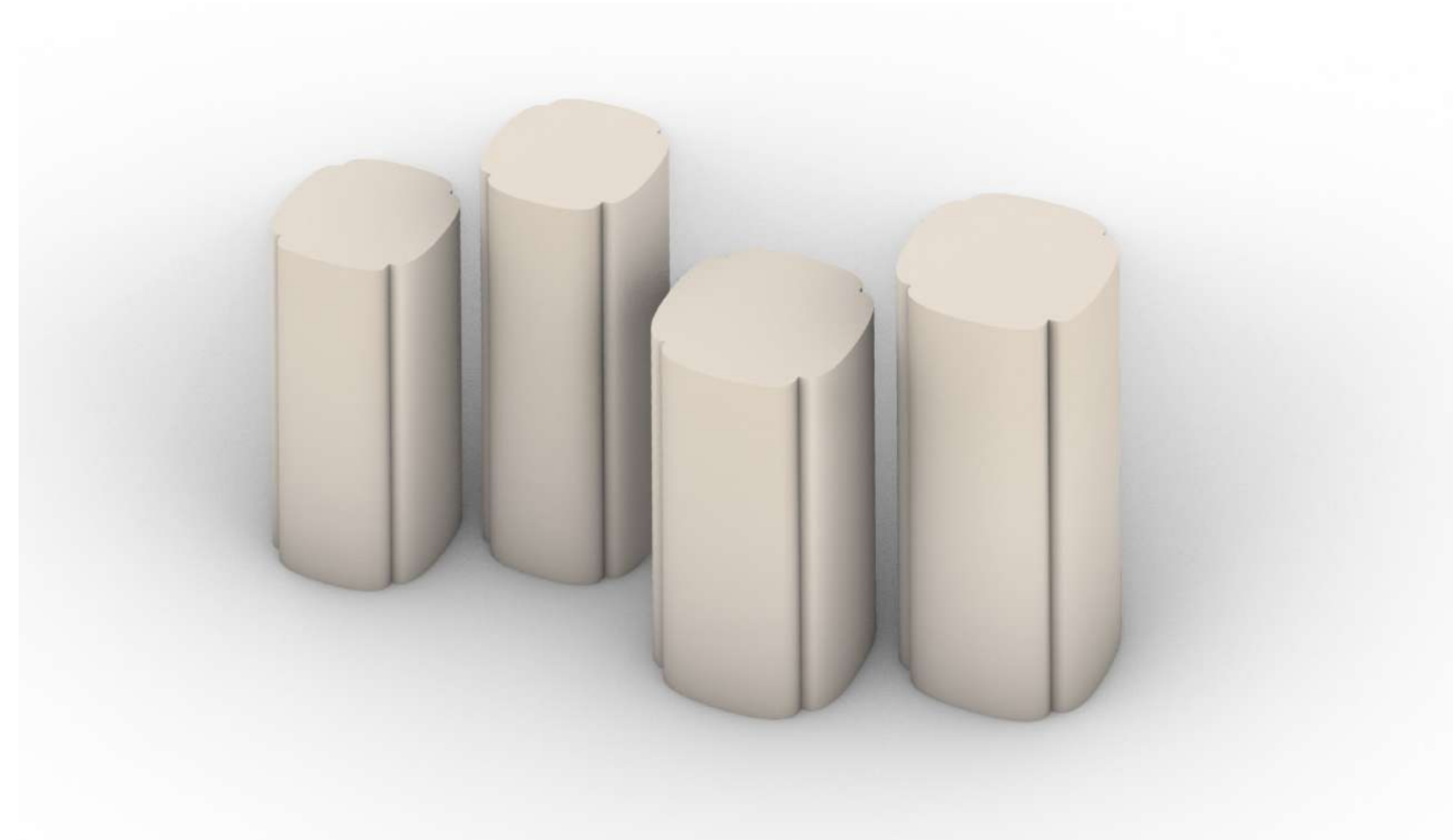

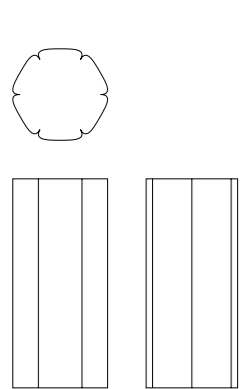

**VITRUVIO N°2  
SQUARE**

small low — HAP184  
cm 36.5 x 35 | h cm 80

Only available in suede.

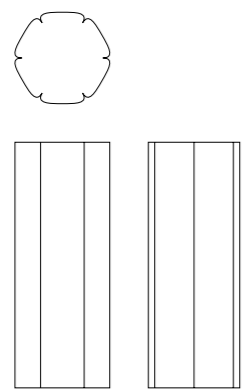

**VITRUVIO N°2  
SQUARE**

small high — HAP189  
cm 36.5 x 35 | h cm 94

Only available in suede.

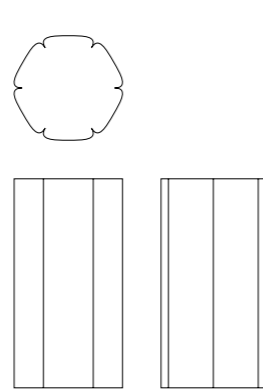

**VITRUVIO N°2  
SQUARE**

large low — HAP194  
cm 41.5 x 40 | h cm 80

Only available in suede.

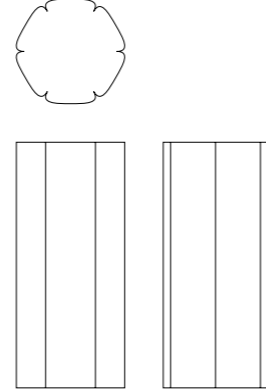

**VITRUVIO N°2  
SQUARE**

large high — HAP199  
cm 41.5 x 40 | h cm 94

Only available in suede.

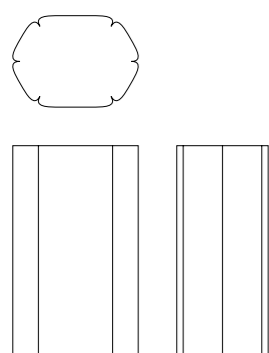

**VITRUVIO N°2  
RECTANGULAR**

small low — HAP204  
cm 48 x 35 | h cm 80

Only available in suede.

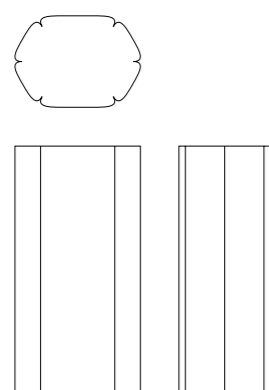

**VITRUVIO N°2  
RECTANGULAR**

small high — HAP209  
cm 48 x 35 | h cm 94

Only available in suede.

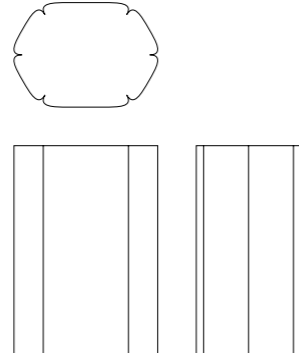

**VITRUVIO N°2  
RECTANGULAR**

large low — HAP214  
cm 55 x 40 | h cm 80

Only available in suede.

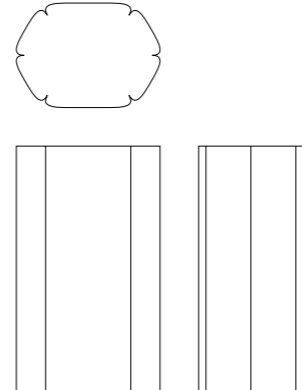

**VITRUVIO N°2  
RECTANGULAR**

large high — HAP219  
cm 55 x 40 | h cm 94

Only available in suede.

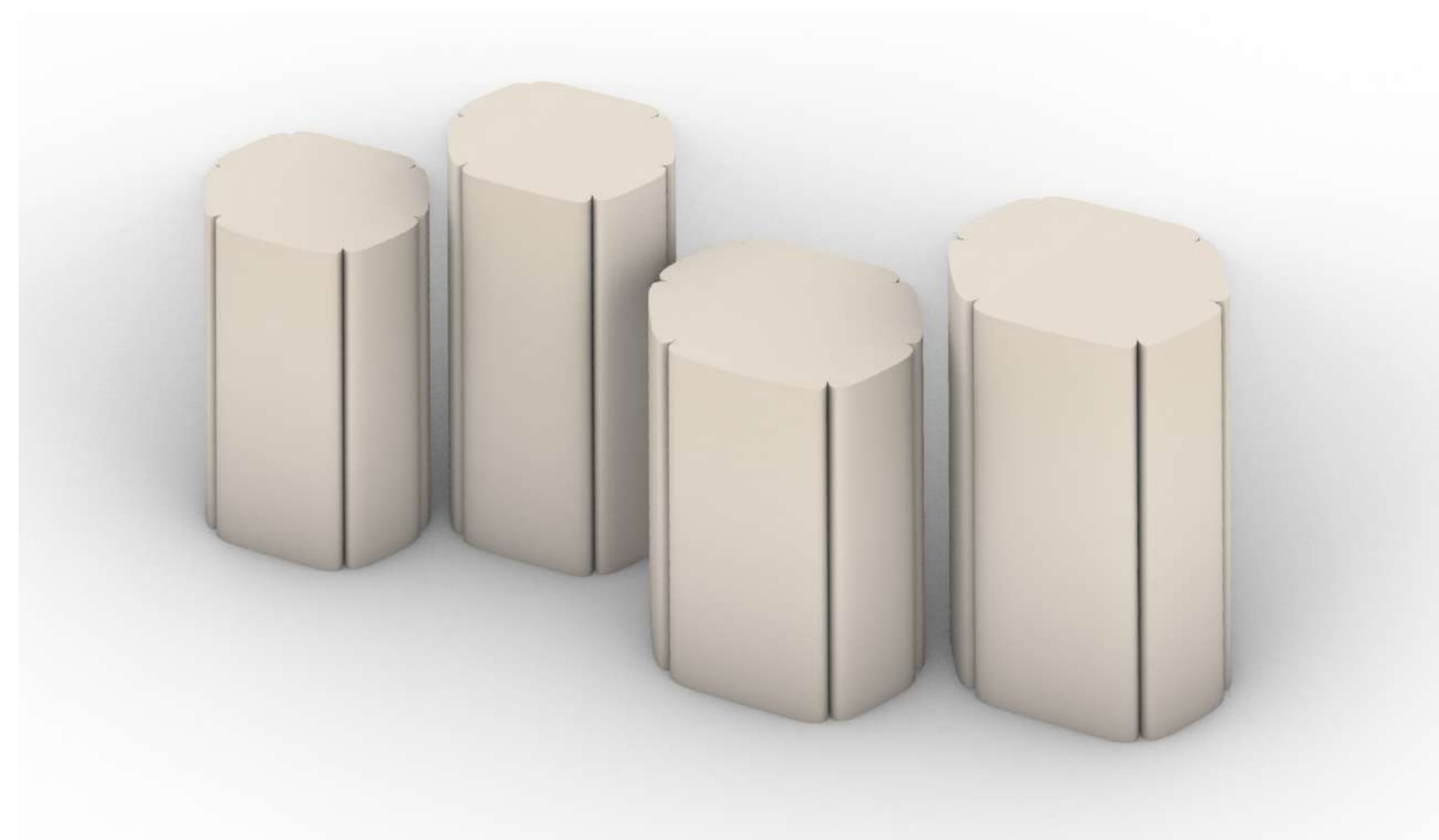
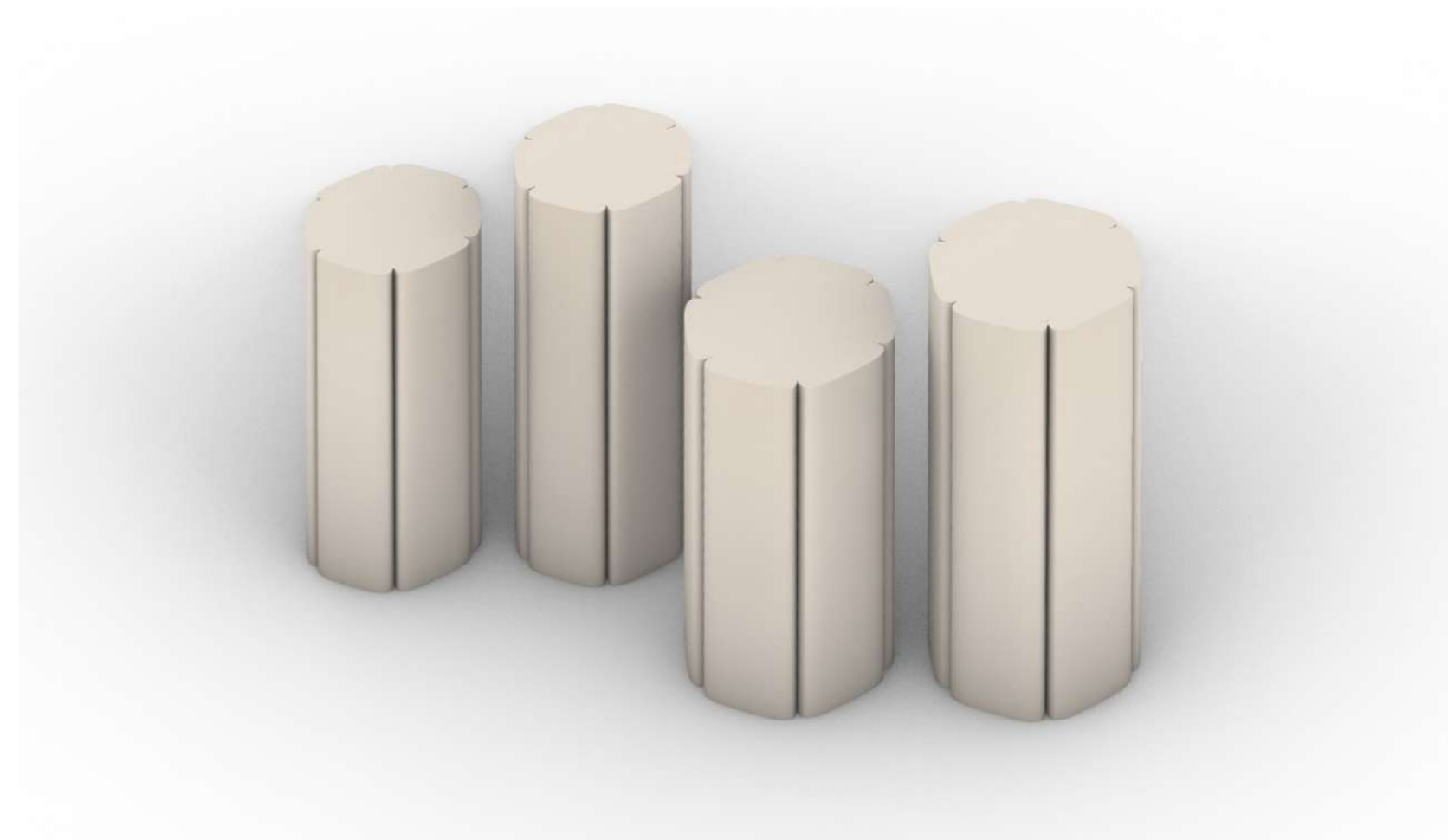

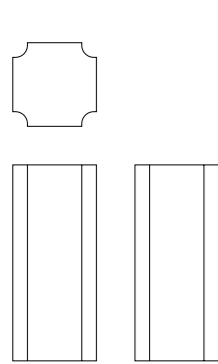

**VITRUVIO N°3  
SQUARE**

small low — HAP182  
cm 32 x 32 | h cm 75

Only available in suede.

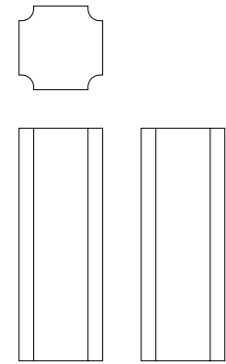

**VITRUVIO N°3  
SQUARE**

small high — HAP187  
cm 32 x 32 | h cm 89

Only available in suede.

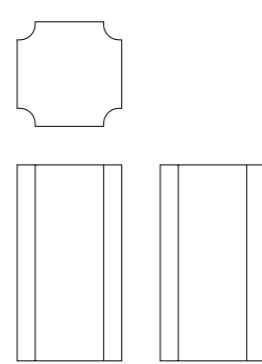

**VITRUVIO N°3  
SQUARE**

large low — HAP192  
cm 40 x 40 | h cm 75

Only available in suede.

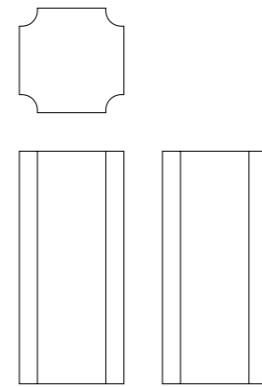

**VITRUVIO N°3  
SQUARE**

large high — HAP197  
cm 40 x 40 | h cm 89

Only available in suede.

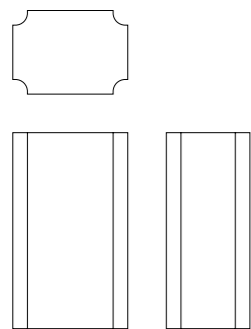

**VITRUVIO N°3  
RECTANGULAR**

small low — HAP202  
cm 44 x 32 | h cm 75

Only available in suede.

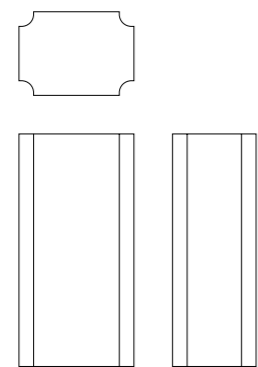

**VITRUVIO N°3  
RECTANGULAR**

small high — HAP207  
cm 44 x 32 | h cm 89

Only available in suede.

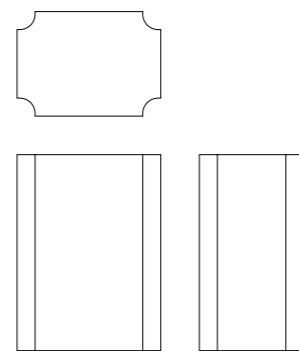

**VITRUVIO N°3  
RECTANGULAR**

large low — HAP212  
cm 55 x 40 | h cm 75

Only available in suede.

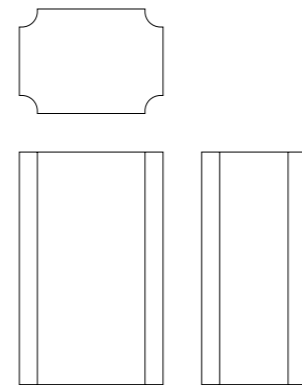

**VITRUVIO N°3  
RECTANGULAR**

large high — HAP217  
cm 55 x 40 | h cm 89

Only available in suede.

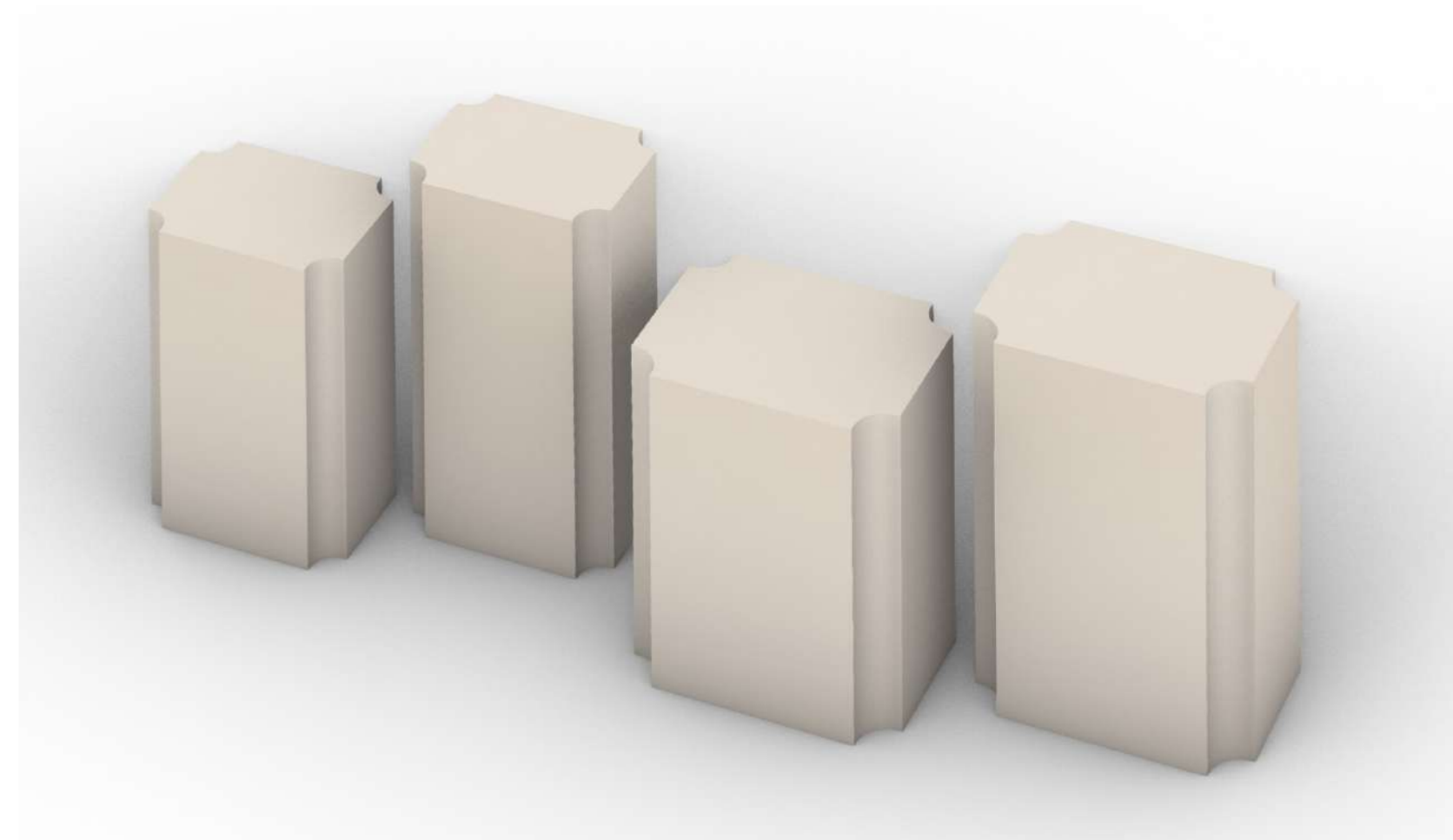
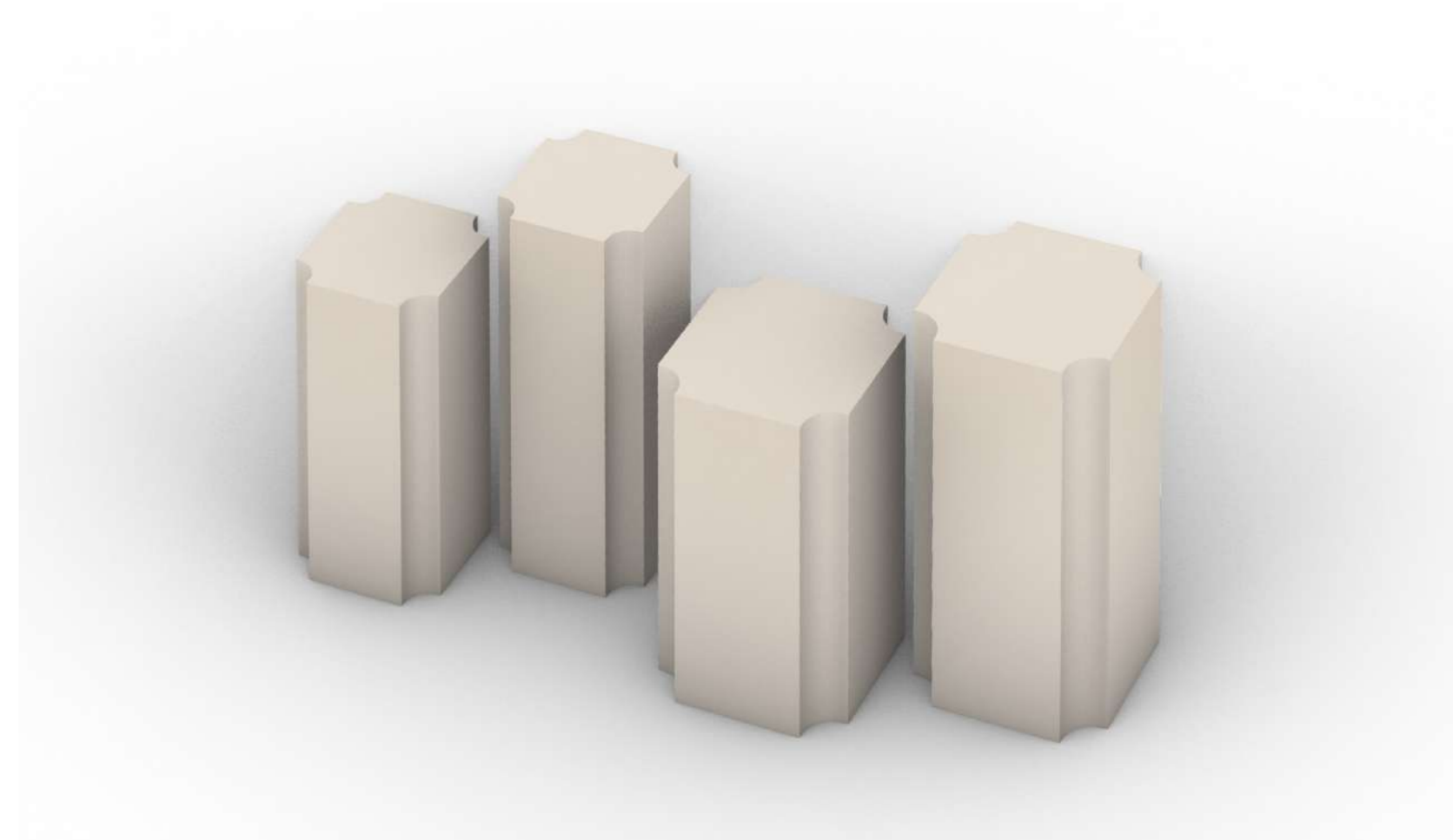

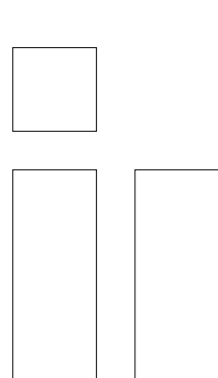

**VITRUVIO N°4  
SQUARE**

small low — HAP181  
*cm 32 x 32 | h cm 80*

Only available in suede.

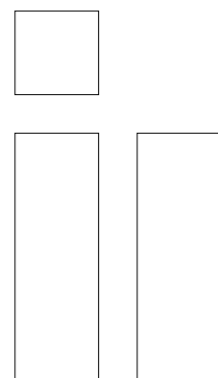

**VITRUVIO N°4  
SQUARE**

small high — HAP186  
*cm 32 x 32 | h cm 94*

Only available in suede.

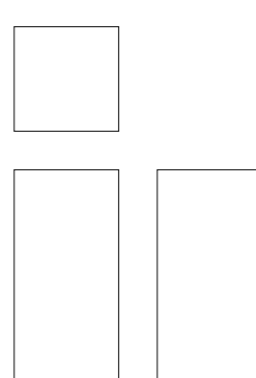

**VITRUVIO N°4  
SQUARE**

large low — HAP191  
*cm 40 x 40 | h cm 80*

Only available in suede.

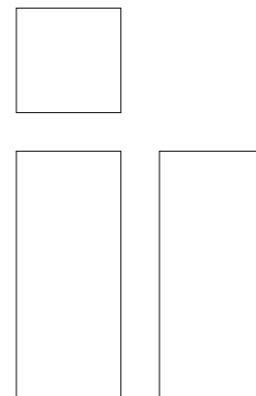

**VITRUVIO N°4  
SQUARE**

large high — HAP196  
*cm 40 x 40 | h cm 94*

Only available in suede.

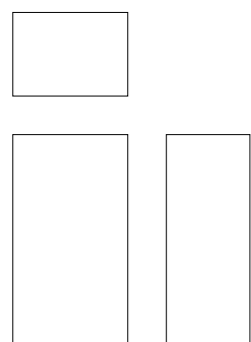

**VITRUVIO N°4  
RECTANGULAR**

small low — HAP201  
*cm 44 x 32 | h cm 80*

Only available in suede.

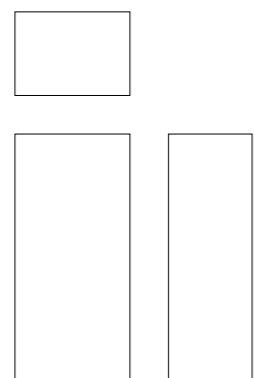

**VITRUVIO N°4  
RECTANGULAR**

small high — HAP206  
*cm 44 x 32 | h cm 94*

Only available in suede.

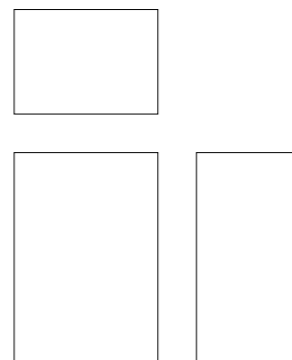

**VITRUVIO N°4  
RECTANGULAR**

large low — HAP211  
*cm 55 x 40 | h cm 80*

Only available in suede.

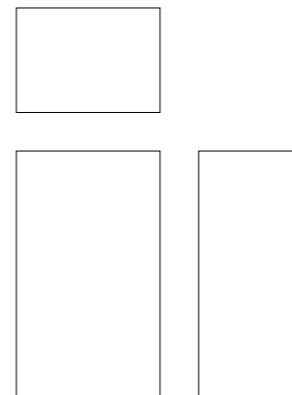

**VITRUVIO N°4  
RECTANGULAR**

large high — HAP216  
*cm 55 x 40 | h cm 94*

Only available in suede.

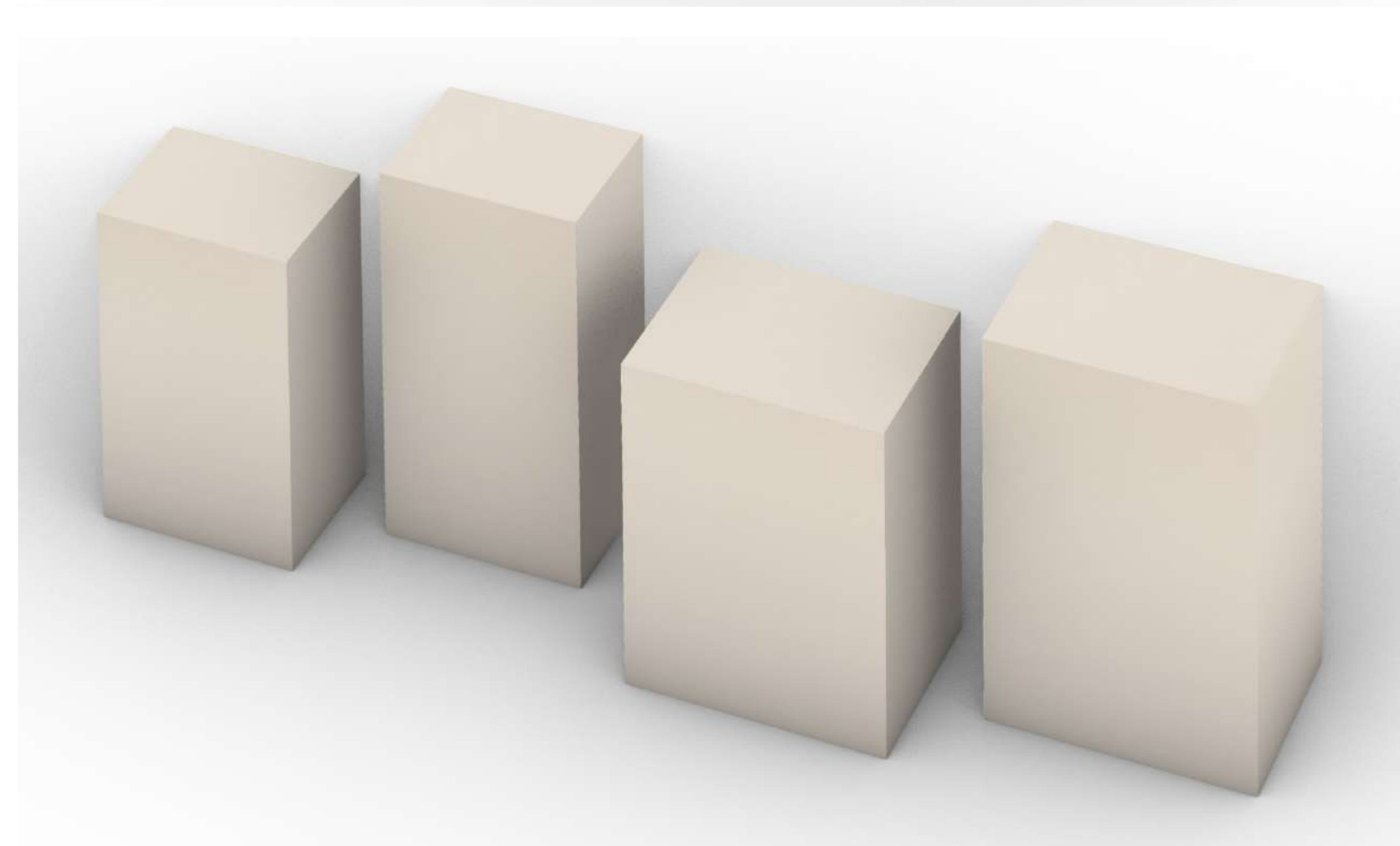
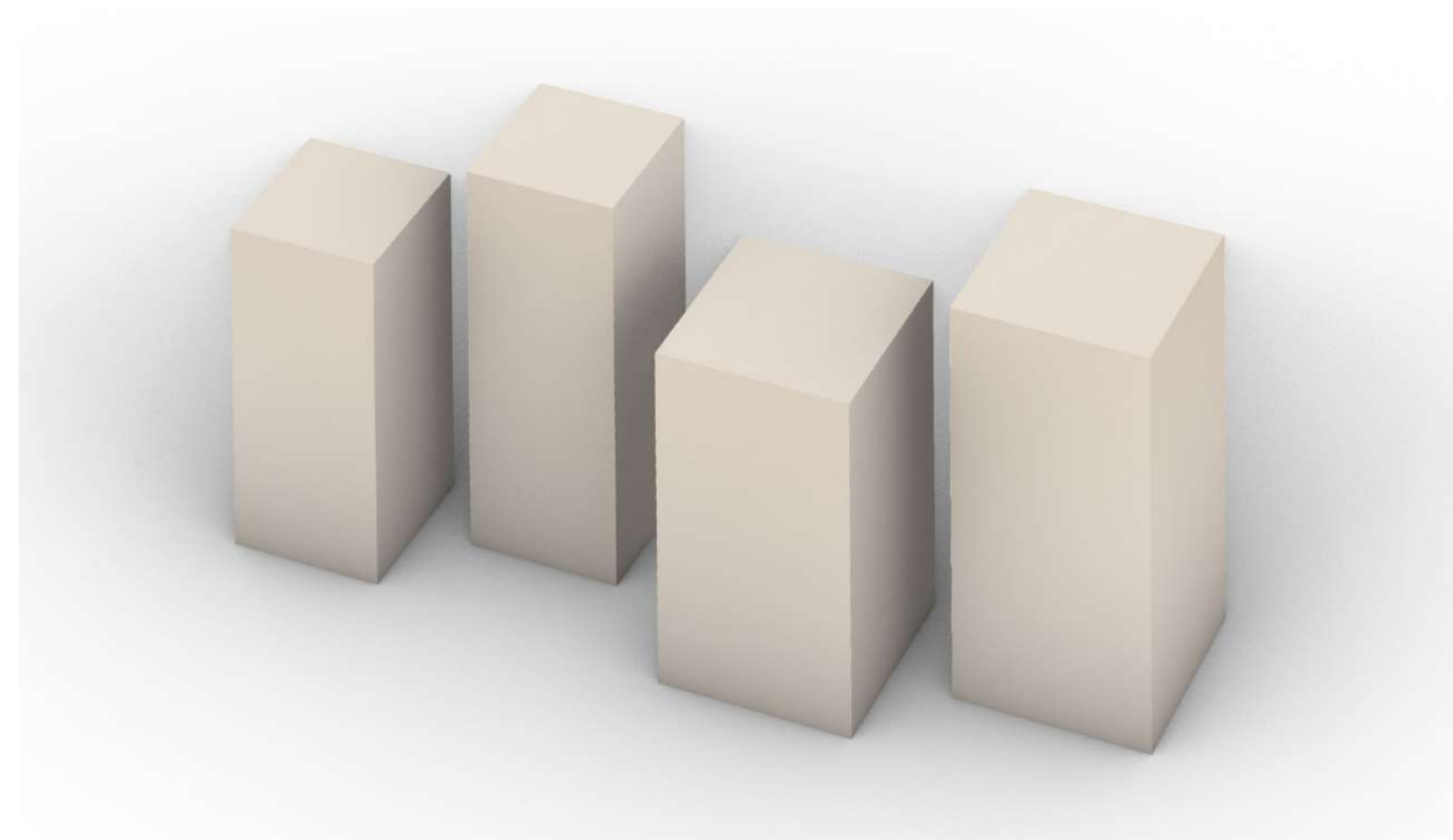

## CHAMPAGNE

The contrast between pure geometric forms, such as the prism and the sphere, has always fascinated the human being.

In a game of references between the architecture of Etienne-Louis Boullée and the surrealist sculptures of Pol Bury, the golden spheres of this collection transform the simple handle of a box into an element of high decoration that invites to come closer and explore its shape and function.

The same spheres, scattered on trays, take us on a travel through metaphysical landscapes.

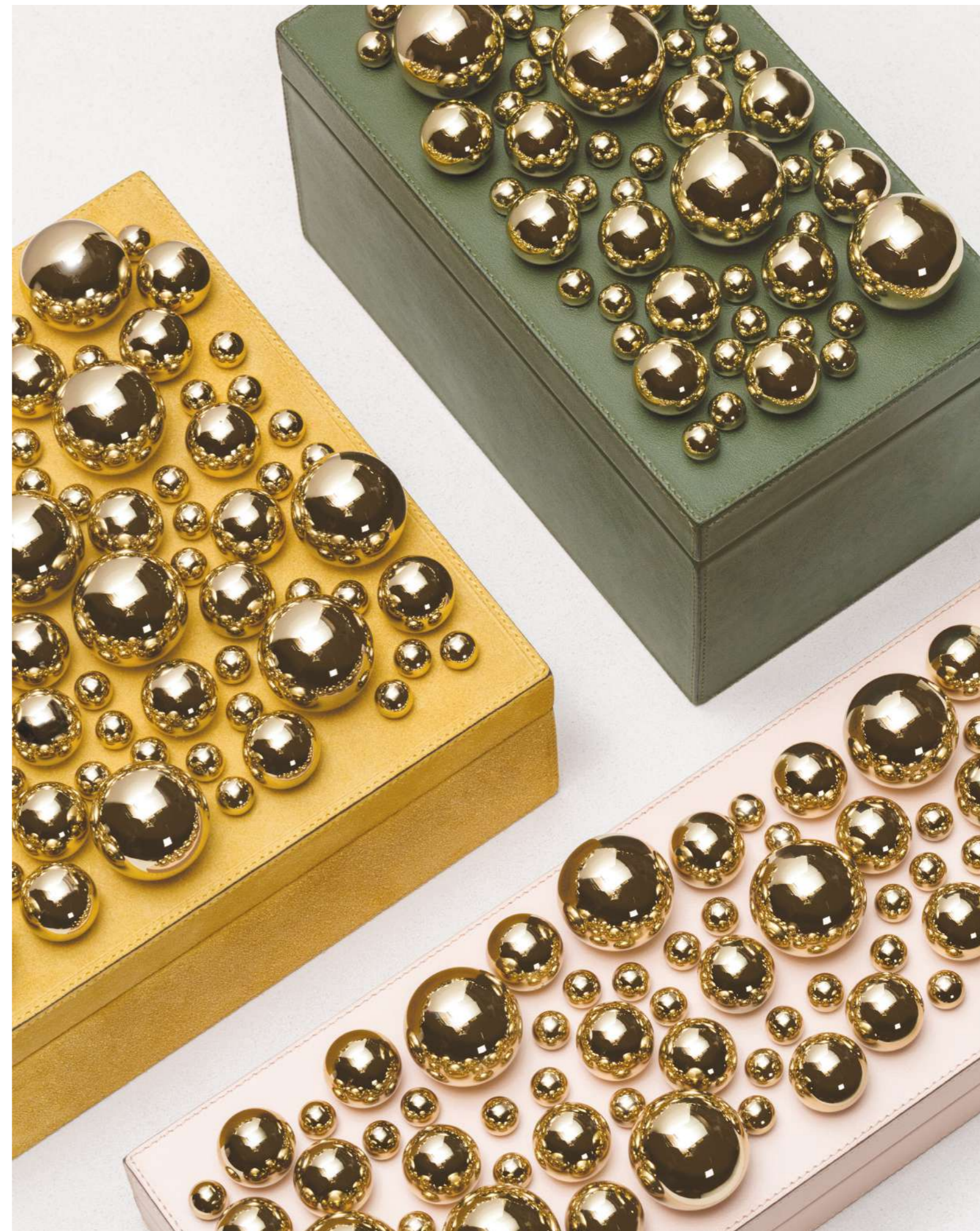

CHAMPAGNE  
VALET TRAY /  
TRAY



valet tray — HVP881  
cm 20 x 20 | h. cm 4.5

tray — TVP884  
cm 38 x 38 | h. cm 4.5

leathers: printed calfskin, suede, nappa



CHAMPAGNE  
5 SPHERES  
BOX



5 spheres rectangular tall — HBP520  
*cm 23 x 13 | h. cm 16.5*

5 spheres square tall — HBP530  
*cm 23 x 23 | h. cm 12.5*

5 spheres long rectangular low — HBP540  
*cm 36 x 13 | h. cm 9*

leathers: printed calfskin, suede, nappa

CHAMPAGNE  
SPHÉRADES  
BOX



sphérades rectangular tall — HBP820  
*cm 23 x 13 | h. cm 16.5*

sphérades square tall — HBP830  
*cm 23 x 23 | h. cm 12.5*

sphérades long rectangular low — HBP840  
*cm 36 x 13 | h. cm 9*

leathers: printed calfskin, suede, nappa



CHAMPAGNE  
SPHÉRADES  
ROUND  
BOX



sphérades small — HBP240  
Ø cm 12.5 | h. cm 12.5

sphérades medium — HBP242  
Ø cm 18.5 | h. cm 12.5

sphérades large — HBP244  
Ø cm 24.5 | h. cm 12.5

leathers: printed calfskin, suede, nappa



## DEW BOXES

Beauty often lies in the smallest details. Dew is a captivating series of round trinket boxes that elevate the art of storage to new heights, transforming trinkets into precious jewels. A trio of trinket boxes in three different sizes, each a testament to meticulous craftsmanship. The allure of fine leather with its sumptuous texture is combined with enchanting plexiglass lids that resemble delicate dewdrops glistening in the morning sun, casting a mesmerizing magnifying lens effect over the treasures within.

It is possible to choose two different colors and textures for the inside and the outside of the box for an even more unique effect.



box n°1 — HBP171  
Ø cm 12.5 | h. cm 15

box n°2 — HBP172  
Ø cm 18.5 | h. cm 12.5

box n°3 — HBP173  
Ø cm 24.5 | h. cm 10

leathers: printed calfskin, suede, nappa



## MEMORY

A nod to the childhood game, this Memory game in leather marquetry draws its inspiration from the 20th-century art and design vocabulary favored by the avant-garde of the Thirties, the works of Sol Lewitt and objects and illustrations by Enzo Mari. It is presented in a leather frame box with a Plexiglass cover.

20 cards — VGP590  
 cm 20 x 20 | h. cm 6  
 card cm 9 x 9

40 cards — VGP591  
 cm 20 x 38 | h. cm 6  
 card cm 9 x 9

leathers: printed calfskin, suede, nappa

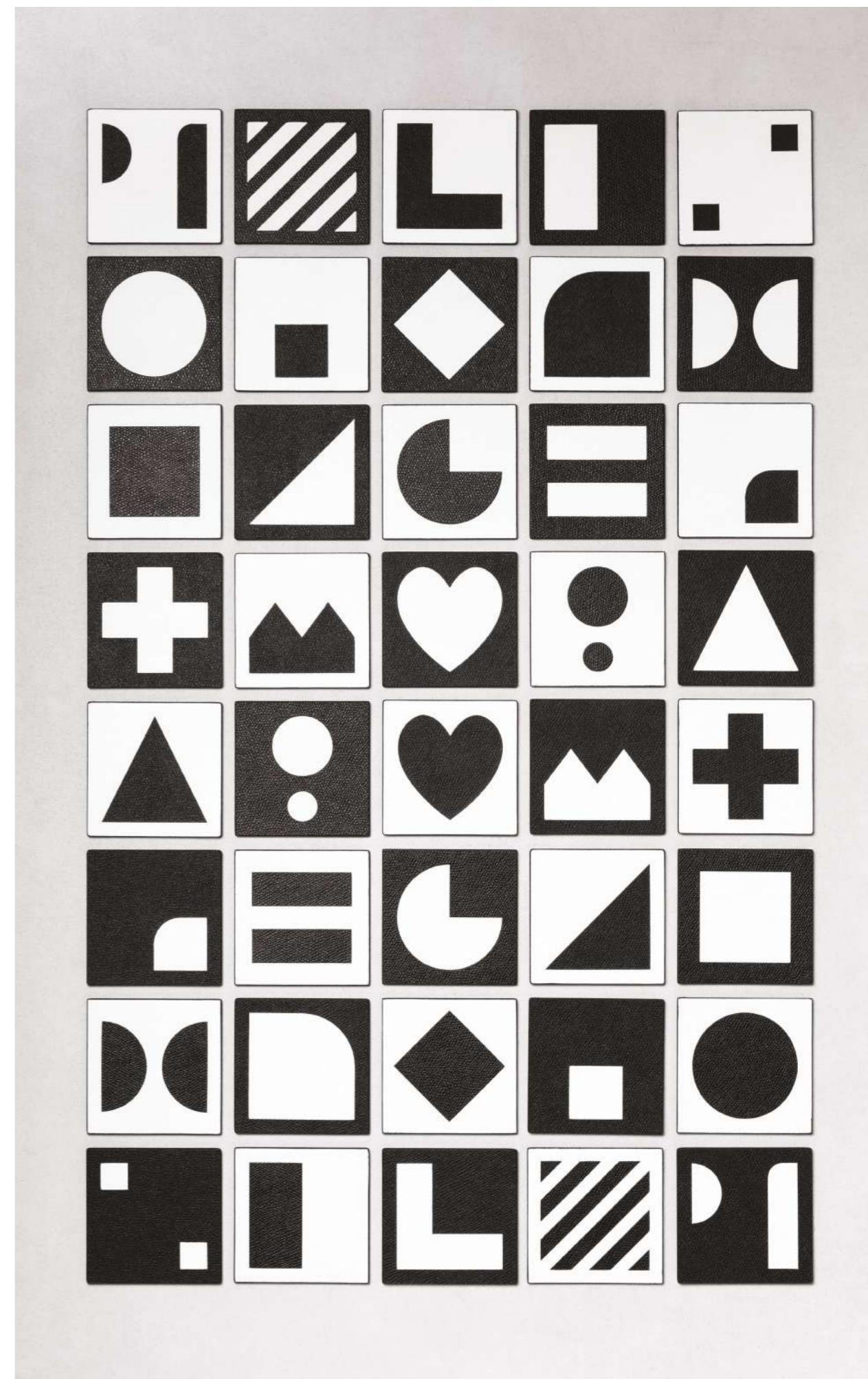

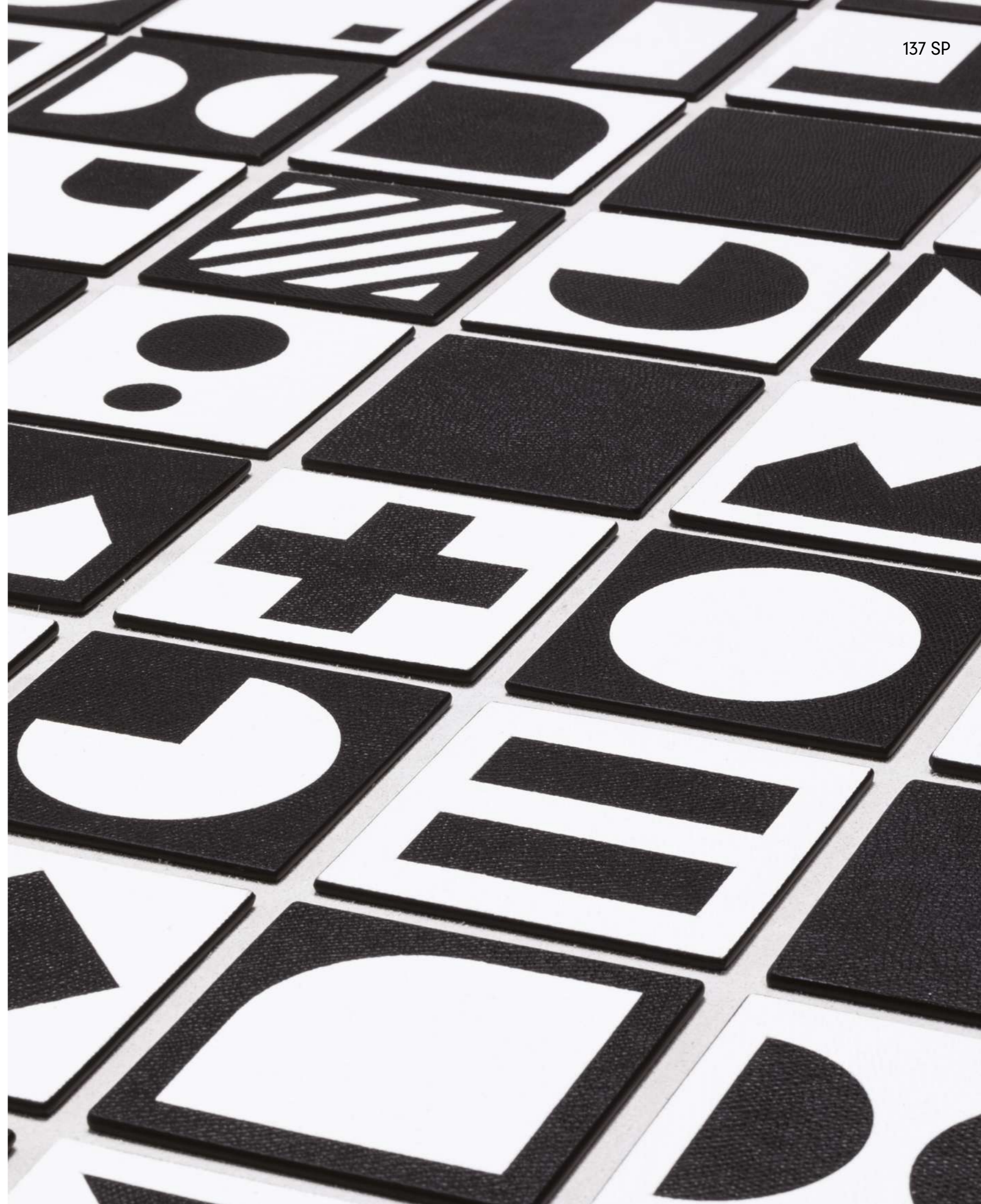

## MIDA

An art deco inspired collection where the golden hinges transform a functional feature into a decorative element.



magazine holder — HAP010  
cm 40 x 19.5 | h. cm 37

square box — HBP170  
cm 23 x 21 | h. cm 8

rectangular box — HBP180  
cm 50 x 21 | h. cm 8

leathers: printed calfskin, suede, nappa  
metal: 24k gold-plated brass



## ROTUNDA BOOKEND

The shape of these bookends pays homage to the public library of Stockholm, the masterpiece of Gunnar Asplund.

The intersection between circle and square is a recurring motif related to knowledge, as in the case of the Vitruvian Man: mankind can fill every shape it wishes, both geometrically and philosophically. Here, the heaviness of the brass cylinder seamlessly connected to the leather-covered square does more than just keeping books in order, adding meaning to any collection displayed in one's home library.



SAP030  
cm 17 x 14.5 | h. cm 14.5

leathers: printed calfskin, suede, nappa



## FLOW

Flow mixes graphic curves with the velvety softness of suede in a line of subtle or bold contrasts ranging from pastels to saturated hues: from boxes for jewelry, cigars, parlor games, tea or secret treasures to bookends, this range is primarily composed of decorative containers to mix and match. An elegant invitation to start a collection.

small jewellery box — GSP031  
cm 27 x 21 | h. cm 10.5

large jewellery box — GSP041  
cm 37.5 x 26.5 | h. cm 12.5

watches box — GSP021  
cm 28.5 x 21 | h. cm 8.5

cufflinks box — GSP010  
cm 21.5 x 11 | h. cm 5.5

small tea box — TAP094  
cm 27 x 21 | h. cm 10.5

large tea box — TAP095  
cm 38 x 22 | h. cm 10.5

small humidor — VSP010  
cm 27.5 x 20 | h. cm 9

large humidor — VSP020  
cm 37.5 x 23 | h. cm 12.5

playing cards holder — VGP010  
cm 8.5 x 7 | h. cm 11

playing cards & dices holder — VGP020  
cm 19 x 12 | h. cm 5

bookend — SAP180  
cm 20 x 16.5 | h. cm 20

leathers: suede + suede











DAZZLE /  
MEMORY /  
FLOW  
PAPERWEIGHT

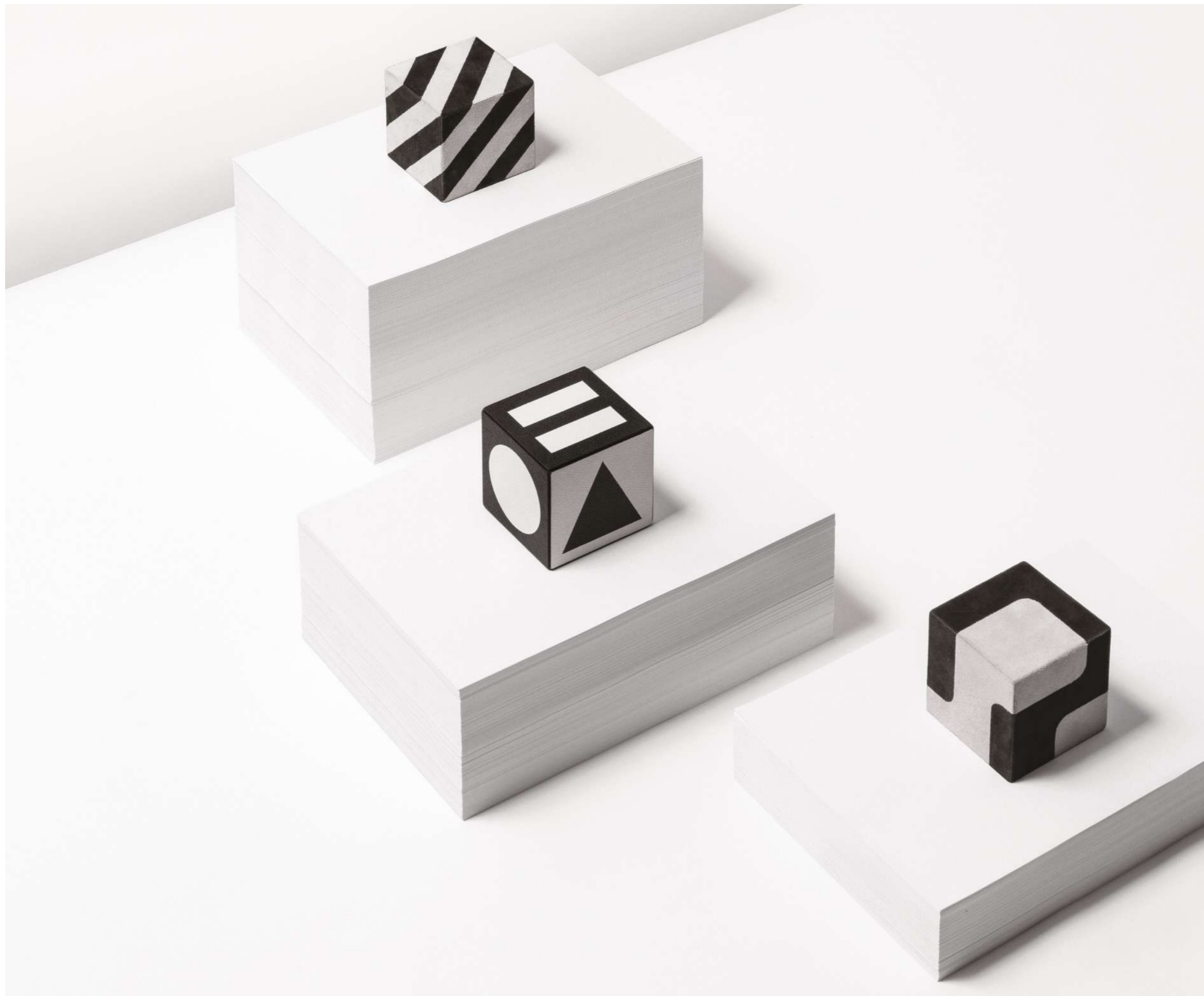

dazzle — SAP300  
cm 8.5 x 8.5 | h. cm 8.5  
leathers: suede + suede

memory — SAP500  
cm 8.5 x 8.5 | h. cm 8.5  
leathers: printed calfskin, suede, nappa

flow — SAP200  
cm 8.5 x 8.5 | h. cm 8.5  
leathers: suede + suede

## PERSONAL ASSISTANT DESK ORGANIZER

As miniature architectural structure with an essential, rigorous design, the Personal Assistant desk organizer is perfect for keeping one's desk clean while adding a touch of unique style to the work-space.

An elegant and functional office accessory that perfectly fits any refined living as well as business ambiances.

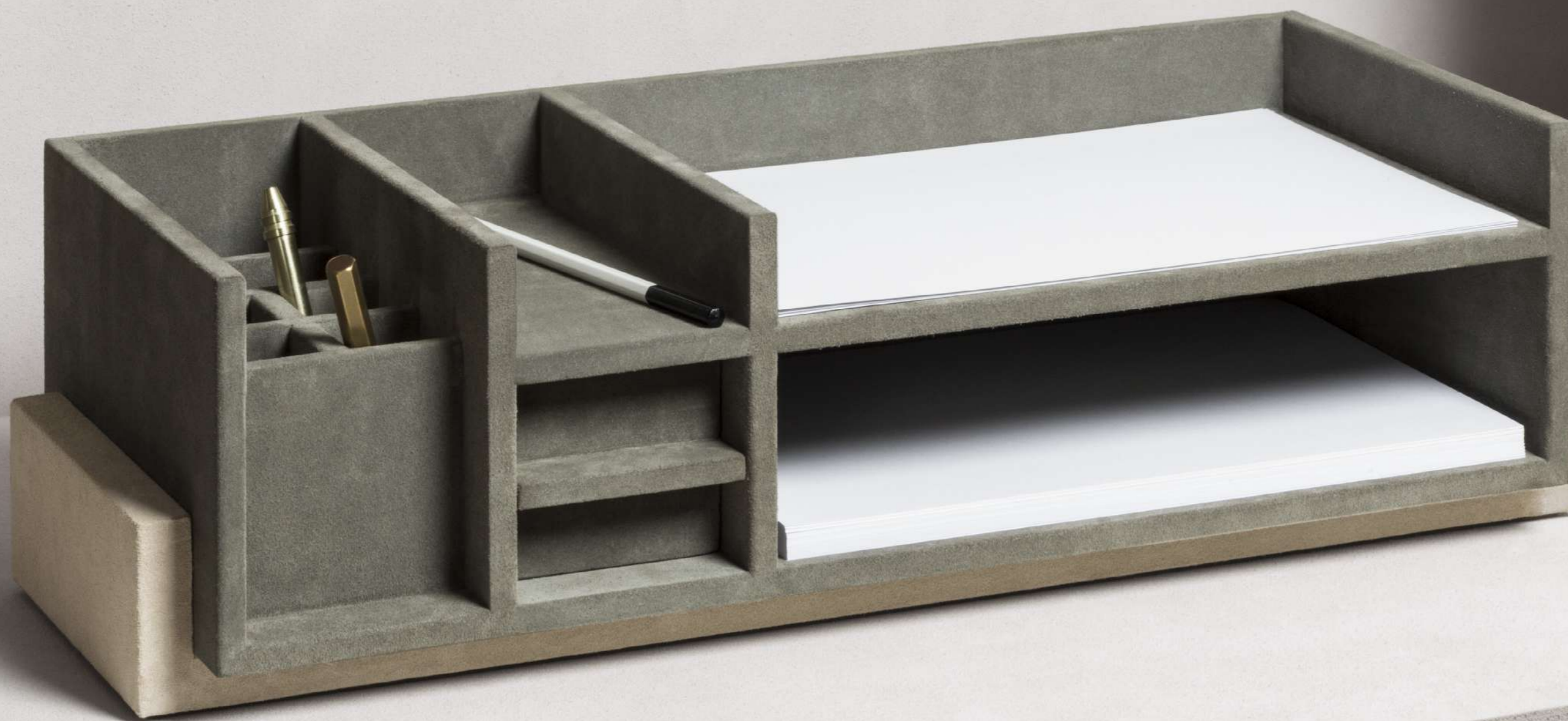

SAP016  
cm 56.5 x 23 | h. cm 16.5

leather: printed calfskin

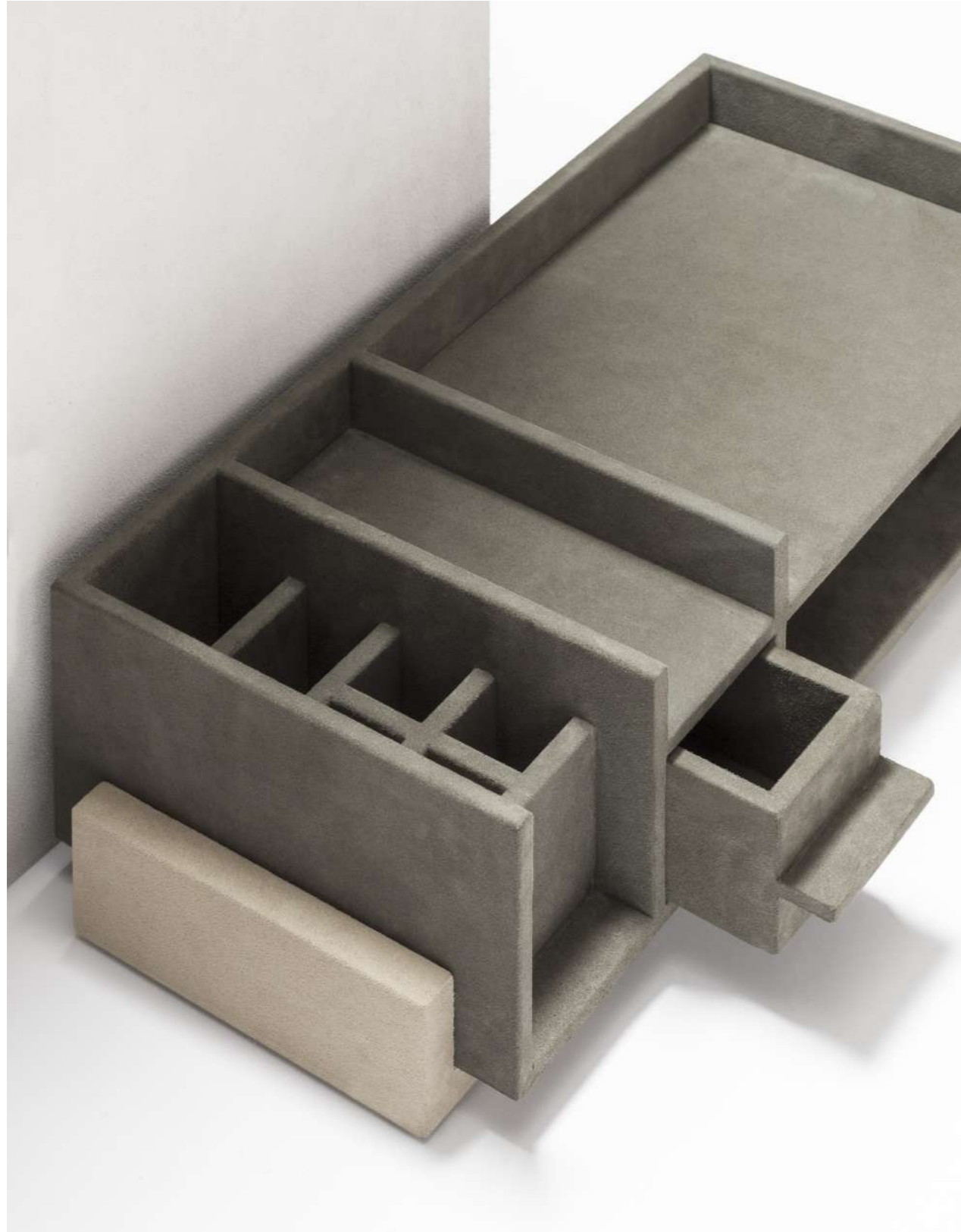

## MALAPARTE

A homage to the celebrated villa built by Adalberto Libera for the writer Curzio Malaparte, a gem of the late-Thirties Italian architecture, this line combines patinated metal and leather, contrasting materials, textures and tones.

Its rigorously structured geometry simultaneously evokes a modernist spirit, the simplicity of Rietveld furniture, and the streamlined Japanese aesthetic, striking a balance between radicalism and sensuality. As nightstands, consoles, desks or desk accessories, the collection expresses the desire to re-establish leather furniture in a contemporary lexicon and a lifestyle that reconciles functionality and aesthetics.



MALAPARTE  
DESK BLOTTER / MOUSE PAD



small mouse pad — SAP100  
*cm 23 x 20 | h. cm 2.5*

large mouse pad — SAP102  
*cm 29 x 23.5 | h. cm 2.5*

small desk blotter — SAP010  
*cm 52.5 x 40 | h. cm 2.5*

large desk blotter — SAP011  
*cm 72.5 x 50 | h. cm 2.5*

leather: suede  
metal: aluminium with bronze finish



MALAPARTE  
DESK BLOTTER / MOUSE PAD  
CARD HOLDER

mouse pad card holder — SAP103  
cm 23 x 17.5 | h. cm 2

desk blotter card holder — SAP013  
cm 70 x 50 | h. cm 2

leather: suede  
metal: aluminium with bronze finish



MALAPARTE  
BIN



bin — SAP145  
cm 25.5 x 25.5 | h. cm 30.5

leather: suede  
metal: aluminium with bronze finish

MALAPARTE  
PAPER HOLDER /  
FILE HOLDER



A4 paper holder — SAP111  
cm 34.5 x 29 | h. cm 6

file holder — SCP080  
cm 29 x 9.5 | h. cm 32

leather: suede  
metal: aluminium with bronze finish

MALAPARTE  
PEN HOLDER / BOX



pen holder — SAP040  
*cm 9.5 x 9.5 | h. cm 10*

box — HBP203  
*cm 33.5 x 16.5 | h. cm 13*

leather: suede  
metal: aluminium with bronze finish



MALAPARTE  
TRAY



tray — TVP010  
cm 52 x 20 | h. cm 3.5

leather: suede  
metal: aluminium with bronze finish





MALAPARTE  
VALET TRAY

small valet tray — HVP105  
*cm 17 x 17 | h. cm 3*

medium valet tray — HVP106  
*cm 25 x 25 | h. cm 3*

large valet tray — HVP107  
*cm 31 x 31 | h. cm 3*

leather: suede  
 metal: aluminium with bronze finish



MALAPARTE  
SIDE TABLE



MAP090  
cm 45.5 x 30.5 | h. cm 49.5

leathers: printed calfskin, suede, nappa  
metal: aluminium with bronze finish

MALAPARTE  
CONSOLE



MCP071  
cm 130.5 x 38.5 | h. cm 92

leathers: printed calfskin, suede, nappa  
metal: aluminium with bronze finish





MALAPARTE  
DESK



MDP041  
cm 148 x 63 | h. cm 80.5

leathers: printed calfskin, suede, nappa  
metal: aluminium with bronze finish

## ALFABETA

The innovative furniture collection is composed of geometric shapes with leather bound legs featuring unconventional proportions and rounded convex and concave forms – the signature design is utilized in a bookend that boasts a strong sculptural quality. Just as in the architecture of Mies van der Rohe, the subtle detailing here never calls attention to itself and meets an inquisitive gaze with a fitting response.



bookend — SAP182  
cm 13.5 x 10 | h. cm 22

leathers: printed calfskin, suede, nappa





bench — HSP145  
cm 125.5 x 47.5 | h. cm 43.5

leathers: printed calfskin, suede, nappa





console — MCP045  
cm 145.5 x 47.5 | h. cm 91.5

leathers: printed calfskin, suede, nappa



dining table — MTP042  
cm 220 x 107.5 | h. cm 75.5

leathers: printed calfskin, suede, nappa

YOYO  
COFFEE TABLE /  
SIDE TABLE /  
STOOL

In a link between Art Deco and Kubrick's Space Odyssey, the bold volumes of these stools or side tables make them statement pieces that can fit different kinds of rooms. The carved motif highlights the perfection of craftsmanship and execution.



coffee table — MTP020  
Ø cm 60.5 | h. cm 37  
fully leather covered

side table — MAP020  
Ø cm 35.5 | h. cm 55  
fully leather covered

stool — HSP020  
Ø cm 35.5 | h. cm 46  
fully leather covered

leathers: printed calfskin, suede, nappa

BINITY /  
TRINITY  
STOOL

The key to these pieces's elegance is an absolute precision of proportions, influenced by the timeless allure of Art Deco.



binity — HSP333  
cm 45.5 x 25.5 | h. cm 45.5  
fully leather covered

trinity — HSP383  
cm 62.5 x 40.5 | h. cm 45.5  
fully leather covered

leathers: printed calfskin, suede, nappa



## RHAPSODY STOOL

This collection reinterprets tradition with a fresh and contemporary visual language, seamlessly blending essential lines with ornate detailing. Here, golden tacks and sumptuous leather pay homage to the craftsmanship of the late 1800s and harmoniously merges the classic and the modern, the adorned and the essential, serving as a bridge between two worlds.

The decorative accents in Rhapsody are not just relics of the past but bold statements of contemporary design.



HSP016  
cm 35.5 x 35.5 | h. cm 45.5

leathers: printed calfskin, suede, nappa





## RHAPSODY FLOOR LAMPS

This collection reinterprets tradition with a fresh and contemporary visual language, seamlessly blending essential lines with ornate detailing. Here, golden tacks and sumptuous leather pay homage to the craftsmanship of the late 1800s and harmoniously merges the classic and the modern, the adorned and the essential, serving as a bridge between two worlds.

The decorative accents in Rhapsody are not just relics of the past but bold statements of contemporary design.



short — LTP011  
Ø cm 44 | h. cm 140

tall — LTP013  
Ø cm 50 | h. cm 173

leathers: printed calfskin,  
suede, nappa



## UNDERCOVER STOOL

This practical stool on wheels, which can be used also as a side table, features two different patterns inlaid in leather inspired by Art Deco designs of Pierre Legrain and Rose Adler, who transformed bookbinding into a medium of playful and dazzling experimentation and craftsmanship.



side lines pattern— HSP030  
cm 40.5 x 27.5 | h. cm 44  
fully leather covered

cross pattern — HSP035  
cm 40.5 x 27.5 | h. cm 44  
fully leather covered

leathers: printed calfskin, suede, nappa

## ATLAS STOOL

Inspired by the basalt natural formations, these stools and side tables on wheels can be matched at will to create infinite geometries, simple and elaborate at the same time.



monochrome — HSP010  
cm 43.5 x 30.5 | h. cm 42  
fully leather covered

bicolor horizontal stripes — HSP011  
cm 43.5 x 30.5 | h. cm 42  
fully leather covered

bicolor vertical stripes — HSP012  
cm 43.5 x 30.5 | h. cm 42  
fully leather covered

bicolor central stripe — HSP013  
cm 43.5 x 30.5 | h. cm 42  
fully leather covered

leathers: printed calfskin, suede, nappa

PALAZZO  
STOOL /  
SIDE TABLE

The Palazzo family enlarges to the world of furniture. Leather covered pure shapes intersecate in a rich composition of solid volumes and void, as a graphic homage to the architecture of Giuseppe Terragni's Novocomun apartment complex in Como (1928), considered the first modern building in Italy.



stool — HSP040  
cm 33 x 33 | h. cm 46

side table — MAP040  
cm 33 x 33 | h. cm 56

cylinder in printed calfskin, suede, nappa  
square base available in suede only



## AURELIA

The often-quoted dictum pronounced in 1756 by Johann Winckelmann on the "noble simplicity and quiet grandeur" of Greek art is captured here in leather-covered column elements set atop simple bases that together express a solemn timelessness.

stool — HSP075  
cm 50.5 x 38.5 | h. cm 43

bench — HSP175  
cm 140 x 38 | h. cm 43

leathers: printed calfskin, suede, nappa





## PANGEA BENCH

This bench features a wooden structure, partially bronze lacquered and partially leather covered. Once again, Stéphane Parmentier's design brings out the sensual side of the object through the correct choice of elements and placing it in equal measure in the sphere of rationality and that of subjectivity. The well known made in Italy quality by Giobagnara is highlighted in an original and elegant blend of materials.



HSP140  
cm 160 x 42.5 | h. cm 42

leathers: printed calfskin, suede, nappa



## OLYMPIA

An extended collection of side tables and seats that mix hard and smooth materials such as travertine, suede, leather and bronze lacquered wood. The shapes evoke both the futuristic architectural ensemble of Oscar Niemeyer's parliament of Brazil and the mild curves of oriental architecture.

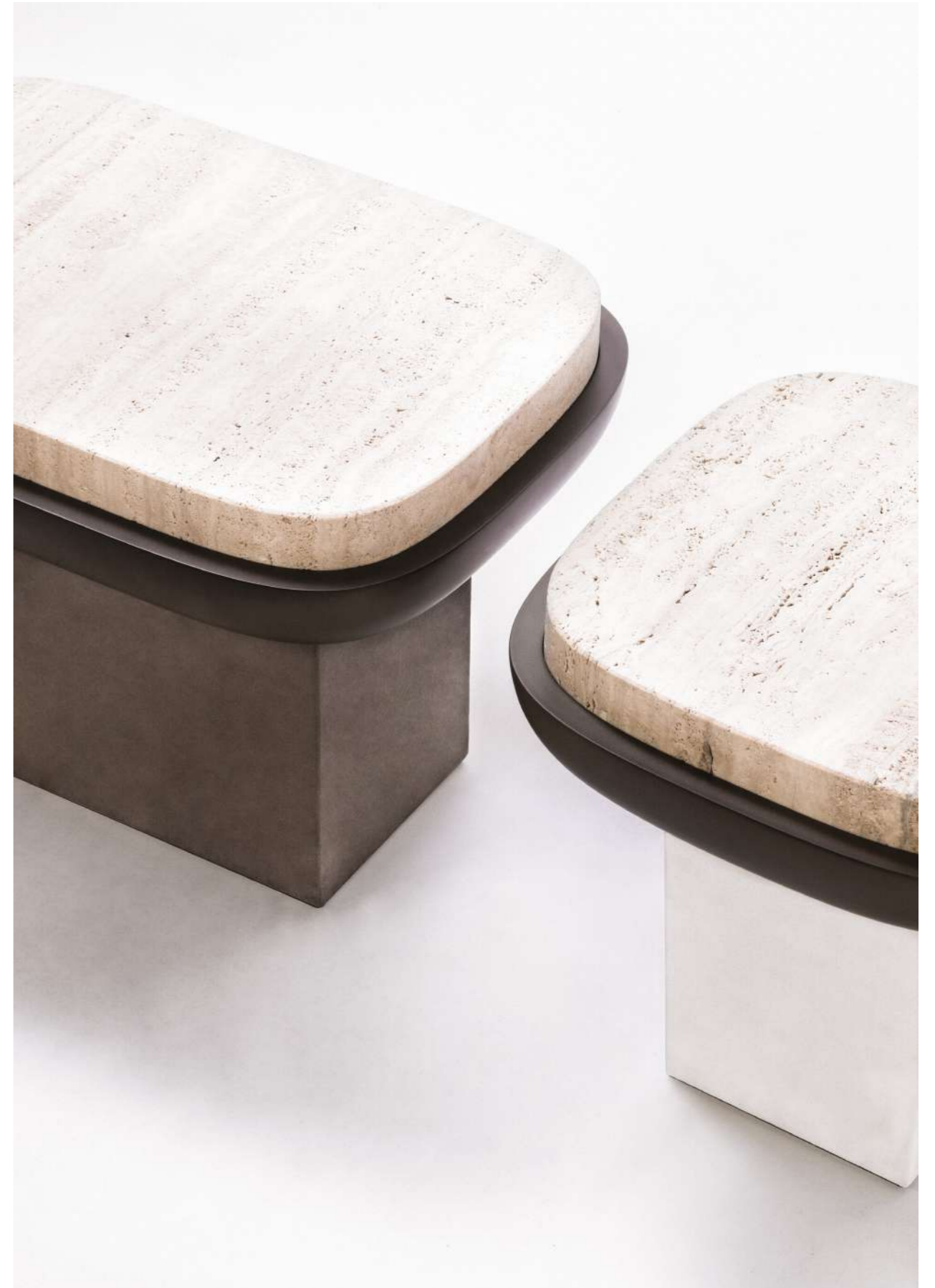



OLYMPIA  
STOOL

square — HSP120  
cm 44.5 x 44.5 | h. cm 40.5

rectangular — HSP125  
cm 64.5 x 44.5 | h. cm 40.5

leathers: printed calfskin, suede, nappa  
bronze laquered wood seat bowl

OLYMPIA MARBLE  
SIDE TABLE

square — MTP120  
cm 44.5 x 44.5 | h. cm 43.5

rectangular — MTP125  
cm 64.5 x 44.5 | h. cm 43.5

leathers: printed calfskin, suede, nappa  
bronze laquered wood seat bowl

OLYMPIA  
STOOL  
& TABLE



HSP121  
cm 83 x 60.5 | h. cm 40.5

leathers: printed calfskin, suede, nappa  
bronze laquered wood seat bowl

OLYMPIA  
COFFEE TABLE



MTP050  
cm 80 x 80 | h. cm 35.5

top in printed calfskin, suede, nappa  
bronze laquered wood structure

## EIGHT OCCASIONAL TABLE

The solid top, made of travertine or leather covered wood, almost floats on the clean lines of the bronze base, creating an effect contemporary and natural at the same time, heavy yet light, mobile yet stationary. A distinctive and lyrical visual vocabulary that performs an exercise of true geometry in the air.



leather top — HSP293  
cm 60 x 36 | h. cm 47

travertine top — HSP293TR  
cm 60 x 36 | h. cm 47

top in printed calfskin, suede, nappa  
bronze legs



## OBLIVION ROUND TRAVERTINE SMALL TABLE

This small occasional table redefines spaces with its unique blend of form and function, effortlessly capturing the essence of balance and beauty. Oblivion boasts slim metal legs that seem to defy gravity, lifting its round top into an enchanting suspension. This top, meticulously fashioned from travertine and colored plaster, adds an air of timeless sophistication to any room, seamlessly blending organic earthiness and contemporary aesthetics.

The metal legs can be either bronze-colored or white. The travertine top's nuance can be either classic or titanium. The top's plaster color matches that of the legs. Custom colors available on request.

Travertine finishes available:



travertino classic



travertino titanium

Metal finishes available:



bronze



white



HSP015

cm 37 x 36 | h. cm 66

table top: h. cm 56

## PALLADIO SIDE TABLES

Palladio is a line of side tables that plays with shapes and materials. Minimal bases clad in the finest Italian leather on which essential, clean forms made of travertine (available in a selection of five nuances) with exquisite details lay: with the aim of bringing together the beauty of Classic Art and a Modern, graphic charm, this combination enhances the diversity of textures and colors, resulting in iconic pieces with a magnetic appeal.

Custom sizes available on request.

Travertine finishes available:



travertino classic   travertino walnut   travertino silver   travertino yellow   travertino red



side table n°1 — HSP022  
Ø cm 36 | h. cm 46.5

side table n°2 — HSP024  
cm 36 x 36 | h. cm 46.5

side table n°3 — HSP026  
cm 50 x 39.5 | h. cm 47

leathers: suede







## FRANKLIN SIDE TABLE

This side table completely covered in leather features an internal balance weight. The delicate silhouette shows a round organic shape that makes it a perfect addition to any interior. A small yet functional piece with a border all around the top which turns it into a valet tray on stand.



MAP050  
cm 22 x 22 | h. cm 52

leathers: printed calfskin, suede, nappa



## AUGUSTUS TABLE

A collection of round nesting tables characterized by bronze legs and smoked glass surfaces, circled by a thick leather edge in a reference to portholes of the greatest Italian ocean liner designs of the 1950s.



small monochrome — MAP131  
 Ø cm 35 | h. cm 35.5

medium monochrome — MAP132  
 Ø cm 49.5 | h. cm 41.5

large monochrome — MAP133  
 Ø cm 66 | h. cm 48

leathers: printed calfskin, suede, nappa  
 top in smoked glass  
 bronze legs

## AUGUSTUS STARGATE TABLE

A collection of round nesting tables characterized by bronze legs and smoked glass surfaces, circled by a thick leather edge in a reference to portholes of the greatest Italian ocean liner designs of the 1950s. It features a subtle leather inlay that accentuates its nautical appearance and adds a touch of understated opulence.



small bicolor — MAP135  
Ø cm 35 | h. cm 35.5

medium bicolor — MAP136  
Ø cm 49.5 | h. cm 41.5

large bicolor — MAP137  
Ø cm 66 | h. cm 48

leathers: printed calfskin, suede, nappa  
top in smoked glass  
bronze legs



## CASCADE

As in the iconic architectural masterpiece of Frank Lloyd Wright, cantilevered leather covered layers seem to float in the air above metal legs, creating coffee tables that are expression of a research of dynamism and rhythm.



CASCADE  
SIDE TABLE  
1



MAP230  
cm 70 x 40 | h. cm 31.5

leathers: printed calfskin, suede, nappa  
metal: bronze  
custom sizes available on request

CASCADE  
SIDE TABLE  
2



MAP240  
cm 70 x 70 | h. cm 43

leathers: printed calfskin, suede, nappa  
metal: bronze  
custom sizes available on request

CASCADE  
SIDE TABLE  
3



MAP250  
cm 80 x 80 | h. cm 28.5

leathers: printed calfskin, suede, nappa  
metal: bronze  
custom sizes available on request

CASCADE  
COFFEE TABLE



MTP230  
*cm 180 x 105 | h. cm 32*

leathers: printed calfskin, suede, nappa  
custom sizes available on request

ATTICA  
SQUARE  
COFFEE TABLE

The charming strength of the Attica collection is due to the combination of the highly geometric aesthetics with velvety leathers, appealing textured parchment and unique wood grains. Each Attica piece is an inimitable creation where materials, edges and curves play a calm symphony of symmetry and balance.

Available with top in parchment or in leather.  
Leather-covered wood base + bronze decorative feet.



parchment — MTP071P  
cm 85 x 85 | h. cm 46.5

leather — MTP071  
cm 85 x 85 | h. cm 46.5  
leathers: printed calfskin, suede, nappa





ATTICA  
ROUND  
COFFEE TABLE

The charming strength of the Attica collection is due to the combination of the highly geometric aesthetics with velvety leathers, appealing textured parchment and unique wood grains. Each Attica piece is an inimitable creation where materials, edges and curves play a calm symphony of symmetry and balance.

Available with top in parchment or in leather.  
Bronze-lacquered wood base + bronze decorative feet.



parchment — MTP072P  
Ø cm 122 | h. cm 37.5

leather — MTP072  
Ø cm 122 | h. cm 37.5  
leathers: printed calfskin, suede, nappa



ATTICA  
LONG  
COFFEE TABLE

The charming strength of the Attica collection is due to the combination of the highly geometric aesthetics with velvety leathers, appealing textured parchment and unique wood grains. Each Attica piece is an inimitable creation where materials, edges and curves play a calm symphony of symmetry and balance.

Available with top in parchment or in leather.  
Smoked brushed pinewood base.



parchment — MTP073P  
cm 199 x 70 | h. cm 42

leather — MTP073  
cm 199 x 70 | h. cm 42  
leathers: printed calfskin, suede, nappa



## SCALA

This line objects was inspired by the “stacked” shape often seen at the base of some buildings in Italy, as well as Salvatore Ferragamo’s celebrated heel. The Scala collection features a selection of furnitures such as stools, tables, end tables, nightstands and sideboards, as well as small interior decor and accessories such as centerpieces, boxes, lanterns and vases, which all have an identical recurring motif, layered and highlighted by deliberately thick legs, that lends a delicate graphic line.

At times, a pure cylindrical shape stands alone; at others a duo or a trio form a stool or occasional table.

The key to these pieces’ elegance is absolute precision of proportions.

A choice of light, dark or muted colours creates the option to match or vary colours and contrasts.

Wallpaper\* Design Awards 2018 Winner

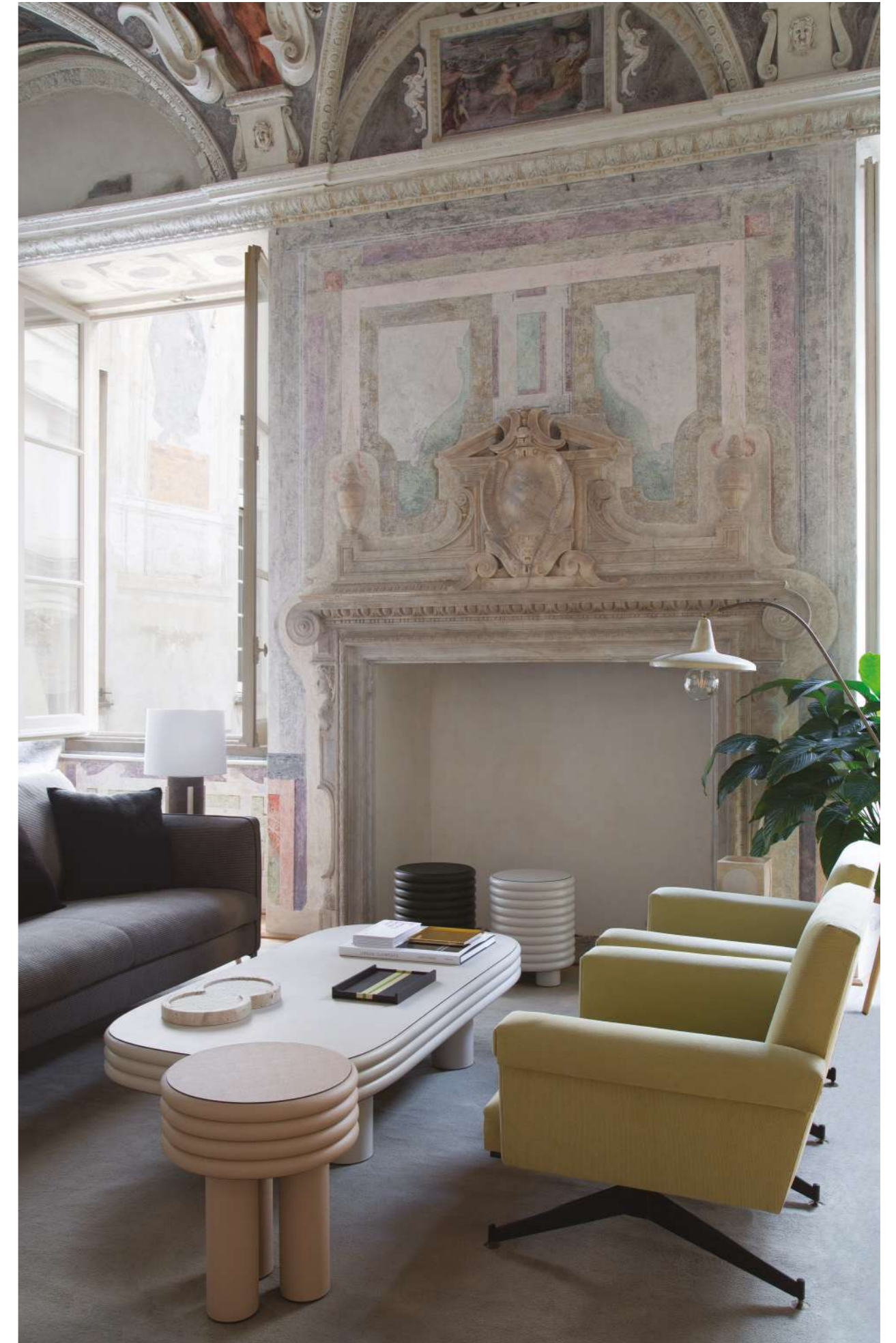

SCALA  
LEATHER  
BOX /  
BOWL



round box — HBP050  
Ø cm 26 | h. cm 13  
fully leather covered

tall round bowl — HAP143  
Ø cm 26 | h. cm 17  
fully leather covered

low round bowl — HAP144  
Ø cm 26 | h. cm 9.5  
fully leather covered

leathers: printed calfskin, suede, nappa

SCALA  
BRONZE  
BOWL

This line objects was inspired by the “stacked” shape often seen at the base of some buildings in Italy, as well as Salvatore Ferragamo’s celebrated heel. The Scala collection features a selection of furnitures such as stools, tables, end tables, nightstands and sideboards, as well as small interior decor and accessories such as centerpieces, boxes, lanterns and vases, which all have an identical recurring motif, layered and highlighted by deliberately thick legs, that lends a delicate graphic line.

At times, a pure cylindrical shape stands alone; at others a duo or a trio form a stool or occasional table.

The key to these pieces’ elegance is absolute precision of proportions.

A choice of light, dark or muted colours creates the option to match or vary colours and contrasts.

Wallpaper\* Design Awards 2018 Winner



Bronze finishes available:



brown black

high round — HAP068  
Ø cm 14.5 | h. cm 13

low round — HAP069  
Ø cm 19.5 | h. cm 8

Structure made with  
burnished bronze casting.



SCALA  
RECTANGULAR  
TRAYS



small — TVP101  
cm 31.5 x 21.5 | h. cm 4.5

medium — TVP102  
cm 38.5 x 28.5 | h. cm 4.5

large — TVP103  
cm 46.5 x 36.5 | h. cm 4.5

leathers: printed calfskin, suede, nappa



SCALA  
ROUND  
TRAYS



small — TVP105  
Ø cm 26.5 | h. cm 4.5

medium — TVP106  
Ø cm 36.5 | h. cm 4.5

large — TVP107  
Ø cm 46.5 | h. cm 4.5

leathers: printed calfskin, suede, nappa



SCALA  
ROUND  
LAZY SUSAN



TVP110  
Ø cm 46 | h. cm 5.5

leathers: printed calfskin, suede, nappa



SCALA  
VASE /  
LANTERN



small — HAP171  
Ø cm 16 | h. cm 24.5

large — HAP173  
Ø cm 19 | h. cm 28

leathers: printed calfskin, suede, nappa



SCALA  
TABLE  
LAMPS



Bronze finishes available:



brown    black

small high — LTP036  
Ø cm 14.5 | h. cm 34.5

large low — LTP037  
Ø cm 19.5 | h. cm 23.5

Burnished sandblasted bronze base  
and opal glass lampshade.





SCALA  
LEATHER  
STOOL /  
COFFEE TABLE

round stool— HSP111  
Ø cm 37 | h. cm 44  
fully leather covered

small high  
coffee table — MTP130  
Ø cm 40.5 | h. cm 46  
fully leather covered

large low  
coffee table — MTP132  
Ø cm 60 | h. cm 31  
fully leather covered

XL low  
coffee table — MTP134  
Ø cm 80 | h. cm 31  
fully leather covered

leathers: printed calfskin, suede, nappa



SCALA  
MARBLE  
STOOL /  
COFFEE TABLES

The iconic form of the celebrated Scala stool and coffee tables, winners of the Wallpaper Design Award, is now translated in stone.

The ribbed shape is brought back to its roots, the stacked base of a Milanese building, and now the silhouette highlight the beauty of different natural stones into sophisticated and timeless pieces of furniture perfectly suitable for both indoor and outdoor use.

Marble finishes available:  
travertino classic / travertino walnut.

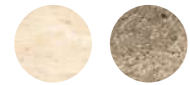

travertino classic    travertino walnut



round stool — HSP111TR  
Ø cm 36 | h. cm 48

small high  
coffee table — MTP130TR  
Ø cm 40.5 | h. cm 46

large low  
coffee table — MTP132TR  
Ø cm 60 | h. cm 31

All made of travertine.  
Choose between travertine classic  
and travertine walnut.





SCALA  
COFFEE TABLES  
ROUND  
WITH ONE LEG



small — MAP451  
Ø cm 60.5 | h. cm 26

medium — MAP452  
Ø cm 60.5 | h. cm 36

large — MAP453  
Ø cm 60.5 | h. cm 46

leathers: printed calfskin, suede, nappa





SCALA  
SQUARE  
COFFEE TABLE



MAP455  
cm 100 x 100 | h. cm 39

leathers: printed calfskin, suede, nappa



SCALA  
LEATHER  
RECTANGULAR  
COFFEE TABLE



MTP140  
cm 160 x 80 | h. cm 37  
fully leather covered

leathers: printed calfskin, suede, nappa



SCALA  
TWO DRAWERS  
CHEST OF DRAWERS



MAP440  
cm 62.5 x 40.5 | h. cm 45.5  
leather-covered top / feet,  
lacquered wood structure

leathers: printed calfskin, suede, nappa  
lacquered wood

SCALA  
THREE DOORS  
SIDEBOARD



MAP430  
cm 180 x 47.5 | h. cm 69  
leather-covered top / feet,  
lacquered wood structure

leathers: printed calfskin, suede, nappa  
lacquered wood

SCALA  
TWO DRAWERS  
NIGHT STAND



MAP070  
cm 122.5 x 40.5 | h. cm 41.5  
leather-covered top/foot,  
lacquered wood structure

leathers: printed calfskin, suede, nappa  
lacquered wood



SCALA  
CONSOLE



MCP053  
cm 140 x 35 | h. cm 85.5

leathers: printed calfskin, suede, nappa



SCALA  
RECTANGULAR  
DINING TABLE



MTP052  
cm 200 x 100 | h. cm 73

leathers: printed calfskin, suede, nappa

284 SP



STEPHANPARMENTIER x GIOBAGNARA

285 SP



STEPHANPARMENTIER x GIOBAGNARA

SCALA  
ROUND  
DINING TABLE



MTP057  
Ø cm 140 | h. cm 75

MTP058  
Ø cm 160 | h. cm 75

leathers: printed calfskin, suede, nappa





SCALA  
SINGLE  
BOOKSHELF

leather — MAP015  
cm 200 x 40.5 | h. cm 143

leathers: printed calfskin, suede, nappa



SCALA  
SINGLE  
BOOKSHELF



wood — MAP017  
cm 200 x 40.5 | h. cm 143

shelves in bronze lacquered wood  
pillars in black carbonized Siberian larch  
(available with smooth lacquer on request)



SCALA  
DOUBLE  
BOOKSHELF



leather — MAP016  
cm 259 x 40.5 | h. cm 143

wood — MAP018  
cm 259 x 40.5 | h. cm 143  
(see reference at pages 68-69)

leathers: printed calfskin, suede, nappa

## VECTOR

The design of these furniture pieces by Stéphane Parmentier has been influenced by the graphic art of the seventies, an era where artists as Victor Vasarely analyzed the formal qualities of what constituted an aesthetic object and studied nature in search of the building blocks of the visual universe. Here, flat surfaces and colliding curves interact as a visual manifestation of the natural geometry of the organic world.



console — MCP020  
cm 160 x 42.5 | h. cm 92

top in printed calfskin, suede, nappa  
back structure available in suede only



296 SP

VECTOR  
BOOKSHELF



MAP021  
cm 202 x 43 | h. cm 160

shelves in printed calfskin, suede, nappa  
back structure available in suede only

297 SP





## PAGODA BOOKSHELF

The dual-purpose design offers the possibility to utilize the piece as a room divider and bookshelf. The sturdy shelving with winglets recalls traditional Far East roof constructions and appears to float on the vertical elements, which may be rotated to function as shelf dividers and which allow for multiple configurations that include creating an attractive background for book storage. Available in a selection of heights and widths.

MAP011  
cm 180.5 x 40.5 | h. cm 176.5

leathers: printed calfskin, suede, nappa  
custom sizes available on request







### BIVIO

Bivio (meaning "junction" in Italian) collection is characterized by an architectural base made of three folded wooden slabs lined in suede and leather. Combined with tops of various shapes, these elements possess a restrained beauty as well as a strong presence that reminds the futuristic shapes of Villa Girasole, an icon of the 20th century Italian architecture.



BIVIO  
CONSOLE



MCP075  
cm 185 x 40 | h. cm 93.5

leathers: printed calfskin, suede, nappa  
custom sizes available on request

BIVIO  
ROUND TABLE



MDP065  
Ø cm 160 | h. cm 75.5

leathers: printed calfskin, suede, nappa  
custom sizes available on request

BIVIO  
COFFEE TABLE



coffee table small — MTP061  
*cm 50.5 x 50.5 | h. cm 40*

coffee table large — MTP063  
*cm 90 x 90 | h. cm 34*

leathers: printed calfskin, suede, nappa  
custom sizes available on request

## LA LINEA

La Linea ("the Line" in Italian) is a name that describes the pleasing visual quality of this collection of tables, desks and consoles where fields of colour are separated by a thin line, as in the paintings of Barnett Newman.

The curves of the legs, a reminder of the array of diverse shapes that occur in nature, connect with ordered rectilinear forms of the upper part by a seamless transition in the geometry.



LA LINEA  
DESK /  
DINING TABLE



MDP022  
cm 240.5 x 100.5 | h. cm 74.5  
fully leather covered

leathers: printed calfskin, suede, nappa  
custom sizes available on request

LA LINEA  
COFFEE TABLE



MTP150  
cm 120.5 x 120.5 | h. cm 36.5  
fully leather covered

leathers: printed calfskin, suede, nappa  
custom sizes available on request

LA LINEA  
CONSOLE



MCP025  
cm 200 x 40.5 | h. cm 91  
fully leather covered

leathers: printed calfskin, suede, nappa  
custom sizes available on request

## STRATOS

The cubic minimal shapes of this line of furniture create a contrast with the refined precision of craftsmanship. As a neobrutalist architecture, designed with recurrent modular volumes, these tables, consoles and desks, feature and convey a sense of immutability that makes them particularly attractive in our chaotic and crumbling world.





STRATOS  
COFFEE TABLE



MTP048  
cm 81 x 70.5 | h. cm 46

top in printed calfskin, suede, nappa  
legs available in suede only

STRATOS  
CONSOLE



MCP048  
cm 165 x 40.5 | h. cm 91

top in printed calfskin, suede, nappa  
legs available in suede only

STRATOS  
DESK



MDP048  
cm 205.5 x 80.5 | h. cm 74

top in printed calfskin, suede, nappa  
legs available in suede only

STRATOS  
TRAVERTINE  
COFFEE TABLE



MTP048TR  
cm 81 x 70.5 | h. cm 46

top in travertine  
legs available in suede only

STRATOS  
TRAVERTINE  
CONSOLE



MCP048TR  
cm 165 x 40.5 | h. cm 91

top in travertine  
legs available in suede only

TEMAKI  
PINEWOOD  
SIDE TABLE

Rooted in the fundamental principles of minimalism and purity of forms, pieces from the Temaki pinewood collection embody sharp sophistication while exuding a natural charm, allowing spaces to breathe while making a bold statement. These creations invite to a journey of form and function, where every piece tells a story of geometric elegance, essential refinement, rigorous artistry, and the charismatic allure of the matching burnished brushed bronze and sandblasted black pinewood.



HSP148  
cm 57 x 70 | h. cm 45.5



TEMAKI  
PINEWOOD  
LOW CONSOLE

Rooted in the fundamental principles of minimalism and purity of forms, pieces from the Temaki pinewood collection embody sharp sophistication while exuding a natural charm, allowing spaces to breathe while making a bold statement. These creations invite to a journey of form and function, where every piece tells a story of geometric elegance, essential refinement, rigorous artistry, and the charismatic allure of the matching burnished brushed bronze and sandblasted black pinewood.



MCP149  
cm 180 x 45 | h. cm 45.5



TEMAKI  
PINEWOOD  
DESK

Rooted in the fundamental principles of minimalism and purity of forms, pieces from the Temaki pinewood collection embody sharp sophistication while exuding a natural charm, allowing spaces to breathe while making a bold statement. These creations invite to a journey of form and function, where every piece tells a story of geometric elegance, essential refinement, rigorous artistry, and the charismatic allure of the matching burnished brushed bronze and sandblasted black pinewood.

It features a built-in leather desk blotter.



MDP025  
cm 220 x 80 | h. cm 75.5

## TEMAKI

Ideal for the home office, bedroom or reception area, the console features two drawers for storage and is supported by slender legs. Sharp corners are accentuated by precision-cut leather inlay that adds three-dimensionality to the piece and highlights the superior craftsmanship.



console — MCP148  
cm 140.5 x 41 | h. cm 98

leathers: printed calfskin, suede, nappa  
legs only available in suede





## TELLARO

Inspired by pavings seen in traditional fishing villages in Liguria, the collection features fluid leather shapes set on mirror frames as well as cabinet drawer fronts that may be used as wall-mounted nightstands or a decorative backdrop.



shelf with drawer — MAP201  
cm 39.5 x 27 | h. cm 15.5

leathers: printed calfskin, suede, nappa  
front stones only available in suede



mirror — MSP214  
cm 59 x 53 x 3.5  
mirror size: cm 48 x 45  
only available in suede



## LACAN DAYBED

This piece redefines the concept of a daybed with its minimal lines and studied simplicity. Lacan captivates with its thin and sharp dark bronze frame, a bold outline that artfully envelops massive primal volumes. This juxtaposition of delicate framework and substantial form creates a visual masterpiece that transcends the ordinary. Wrapped by the frame, a fine leather base exudes luxury, while the mattress, dressed in precious fabric, promises comfort beyond compare. Lacan is more than just a daybed; it's a transformative piece of furniture. It opens up spaces and becomes a focal point where conversations flow and relaxation reigns supreme.

Custom fabric and sizes available on request.



MAP501  
cm 220 x 90 | h. cm 60  
seat height: cm 44

leathers: printed calfskin, suede, nappa



fabric in the picture: DEDAR // CHAPEAU | code 016 — cammello

## HORIZON BED

Resulting from the combination of the most skillful craftsmanship with a minimal contemporary design, Horizon boasts both sculptural aesthetics and clever functionality. As an ensemble, it hosts a couple side tables with push-pull mechanism and a mattress that can incorporate a container underneath. All the upper volumes are dressed in the finest Italian leather and float on an elegant wood platform, creating an overall balance of clean lines.

Wood finishes available:  
dark walnut / wenge.



dark  
walnut

wenge





Horizon I — MAP031  
 cm 305 x 210 | h. cm 123  
 mattress top height: cm 50

Horizon I with container — MAP036  
 cm 305 x 210 | h. cm 123  
 mattress top height: cm 50

The mattress is not included in the ensemble.  
 Mattress suggested thickness: cm 20 - 25.



Horizon II — MAP041  
 cm 305 x 210 | h. cm 123  
 mattress top height: cm 50

Horizon II with container — MAP046  
 cm 305 x 210 | h. cm 123  
 mattress top height: cm 50

The mattress is not included in the ensemble.  
 Mattress suggested thickness: cm 20 - 25.



## INIZIO KEYRING

Inizio evokes encounters and happy beginnings — in friendship, in love, in life. Three styles of multi-coloured keychain remind the theme of two intertwined geometric shapes (circles, hearts, rectangles with rounded corners), a motif that serves as a pretext for subtle, irresistibly alluring plays on colour.

double circle — PBP808  
*cm 7 x 5*

double rectangle — PBP404  
*cm 8.5 x 4*

double heart — PBP303  
*cm 6 x 6*

leathers: golf, nappa, shagreen  
recommended colours' combinations at pages  
200, 201, 202

## IRIDE KEYRING

keyhole — PBP101  
*cm 11 x 5*  
*with printed nappa eye*

leathers: printed calfskin, nappa

## ECLIPSE / SUNSET KEYRING

eclipse (4 rings) — PBP202  
*cm 9 x 3*

sunset — PBP203  
*cm 6 x 4.5*

leathers: printed calfskin, nappa, shagreen







## RABITTI 1969

In 2015, GIOBAGNARA acquired the famous Italian saddle leather specialist RABITTI. Rudi Rabitti, who launched the company in Milan in 1969, was a pioneer: his was the first brand to offer a wide array of home accessories in this type of leather.

He quickly won an international reputation. With RABITTI 1969, GIOBAGNARA is expanding its offer, both by revisiting the house archives and creating new collections.

## ATARI COLLECTION

Stéphane Parmentier designed this collection along the principle of a grid, like the first video games that appeared in the late Seventies.

The primary forms are combined with the preciousness of vegetable-dyed leather, making them statement pieces where the idea of a simple shape is translated into a 3D structure that refers to minimalist art and conceptualism. Rectangular cuts reveal the leather's thickness, underscoring the resolutely graphic aspect of each piece and evoking the perforated cards used for the first musical recordings and the earliest computers.



ATARI JAY  
ARMCHAIR

8040  
cm 86 x 100 | h. cm 73  
seat h. cm 37  
cushions upholstered in leather

recommended colours' combinations at page 186  
custom sizes available on request

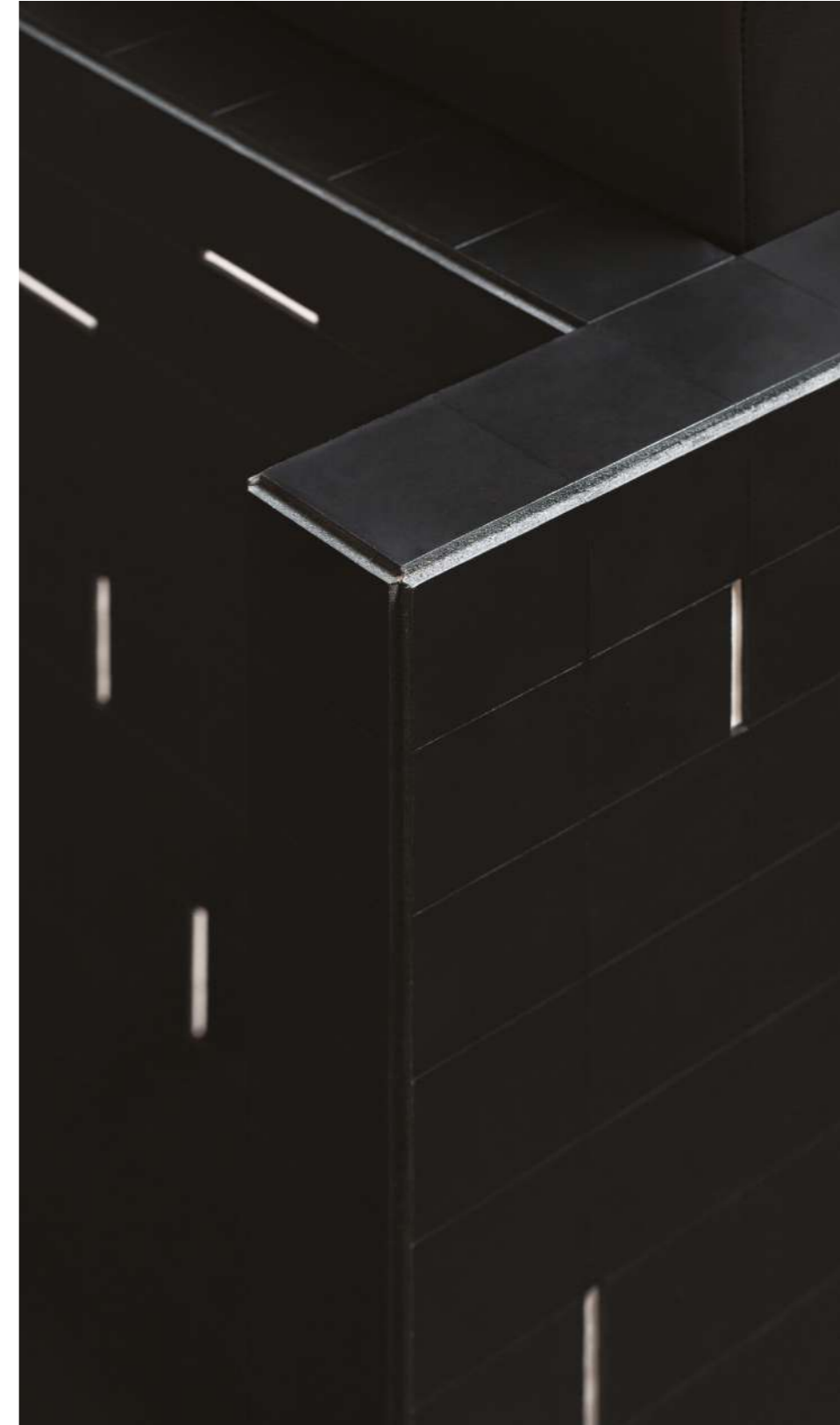

ATARI  
NIGHTSTAND



8030  
cm 41 x 41 | h. cm 56  
*hidden wheels underneath*

recommended colours' combinations at page 186  
custom sizes available on request

ATARI  
STOOL



8020  
cm 41 x 41 | h. cm 47  
*hidden wheels underneath*

recommended colours' combinations at page 186  
custom sizes available on request

ATARI  
COFFEE  
TABLE I

8051  
*cm 81 x 81 | h. cm 40.5*

recommended colours' combinations at page 186  
protective glass top and/or custom sizes are available  
on request



ATARI  
COFFEE  
TABLE II

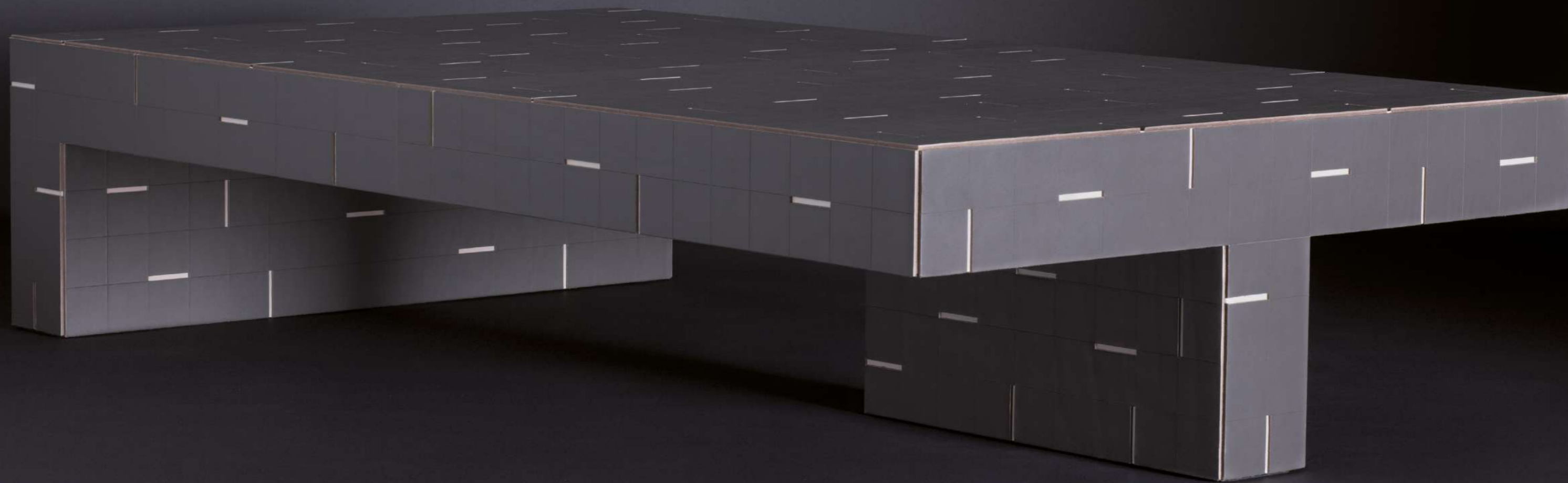

rectangular — 8060  
cm 141 x 81 | h. cm 30.5

recommended colours' combinations at page 186  
protective glass top and/or custom sizes are available  
on request

ATARI  
CONSOLE



8070  
*cm 140.5 x 40.5 | h. cm 85.5*

recommended colours' combinations at page 186  
protective glass top and/or custom sizes are available  
on request



ATARI  
ALBERS  
MIRROR

8085  
cm 85 x 85 x 8  
mirror size: cm 25 x 25

recommended colours' combinations at page 186  
custom sizes available on request

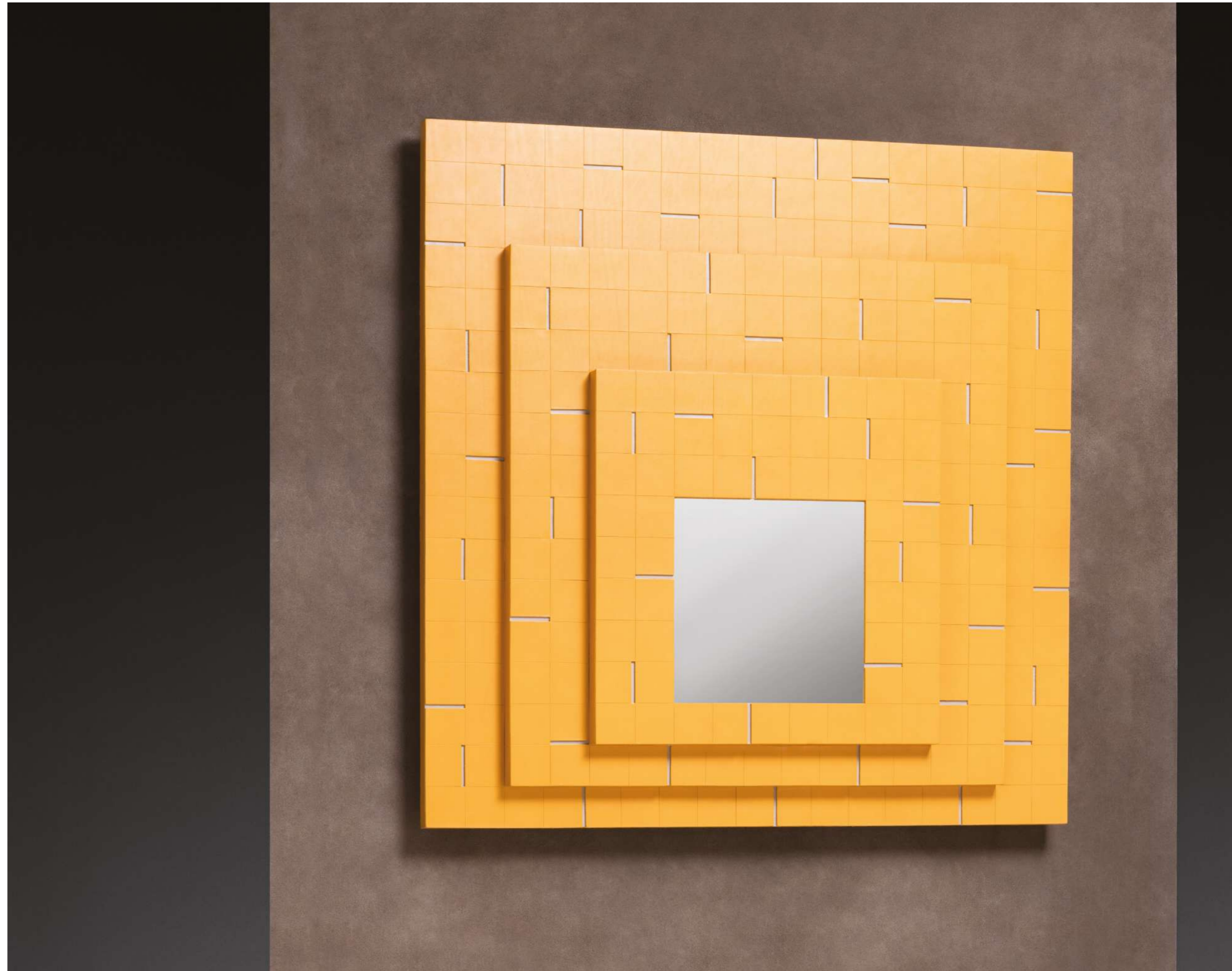

ATARI  
SQUARE  
MIRROR

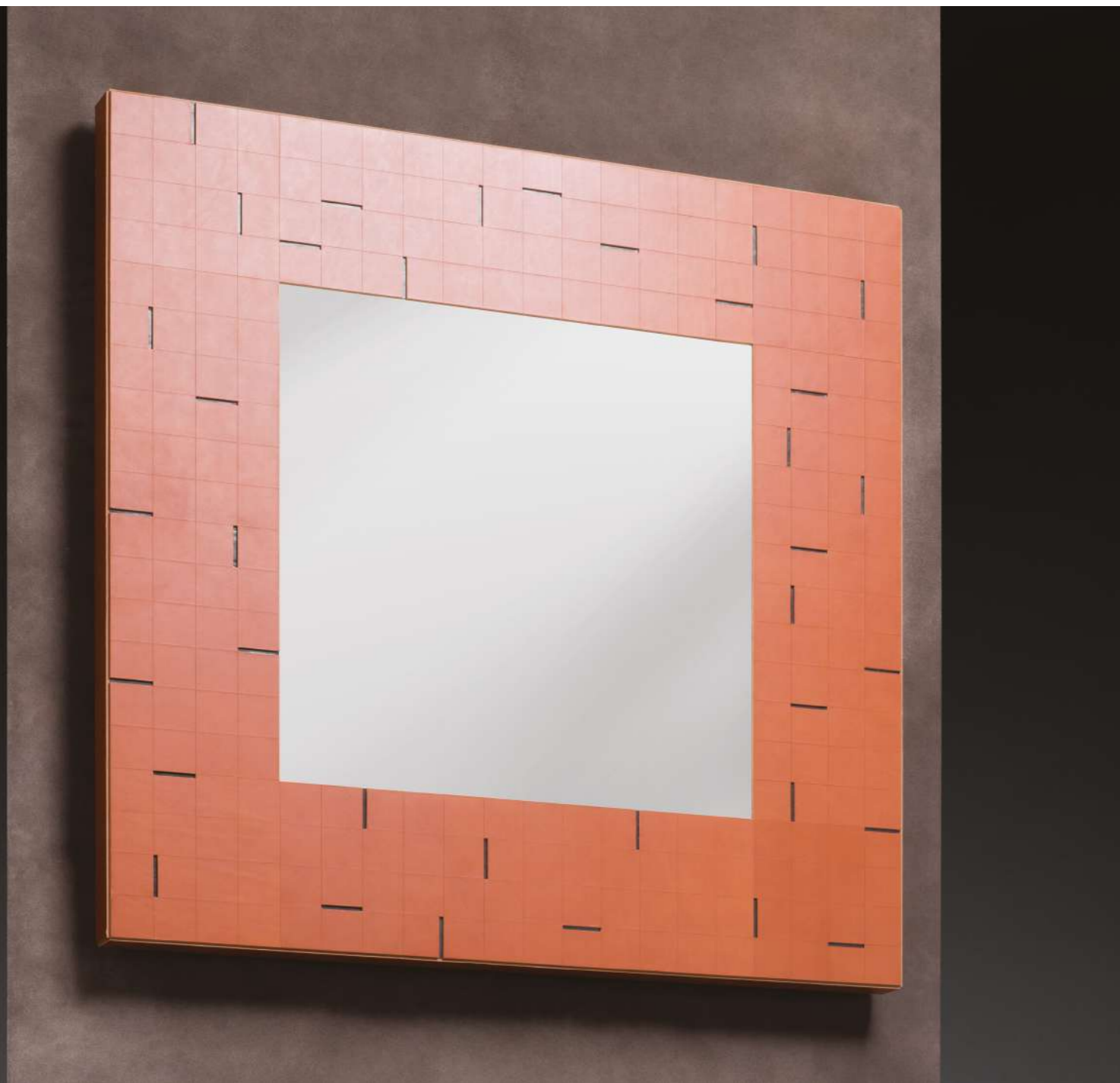

8080  
cm 101 x 101 x 5.5  
mirror size: cm 60 x 60

recommended colours' combinations at page 186  
custom sizes available on request

ATARI  
STICK  
MIRROR



n°1 — 8090  
cm 211 x 11 x 10

n°2 — 8091  
cm 211 x 26 x 10

n°3 — 8092  
cm 211 x 46 x 10

custom sizes available on request  
recommended colours' combinations at page 186

ATARI  
TABLE  
LAMP

small — 8111  
Ø cm 27 | h. cm 43

large — 8113  
Ø cm 36.5 | h. cm 60

recommended colours' combinations at page 186  
custom sizes available on request



ATARI  
PAPERWEIGHT

8100  
 cm 8 x 8 | h. cm 8  
 pattern size: cm 2.5 x 2.5

recommended colours' combinations at page 186

ATARI  
BOX

long rectangular — 8140  
 cm 36 x 13.5 | h. 6  
 pattern size: cm 2.5 x 2.5

tall square — 8130  
 cm 23 x 23 | h. 13.5  
 pattern size: cm 2.5 x 2.5

tall rectangular — 8120  
 cm 23.5 x 13 | h. 18.5  
 pattern size: cm 2.5 x 2.5

recommended colours' combinations at page 186

## SADDLE LEATHER RECOMMENDED COMBINATIONS FOR ATARI COLLECTION



All leathers are provided with a water resistant finish.  
Thanks to an exclusive treatment, the saddle leather  
dries perfectly, doesn't lose its characteristics and  
doesn't leave color stains after being in contact with water.  
Ideal for towel baskets.



**FINISHES**

G — PRINTED CALFSKIN GOLF  
price category: A

tanned in Italy • origin: Northern Europe • price category: A  
waterproof, scratchproof



G — PRINTED CALFSKIN GOLF  
price category: A

tanned in Italy • origin: Northern Europe • price category: A  
waterproof, scratchproof



G — PRINTED CALFSKIN GOLF  
price category: A

tanned in Italy • origin: Northern Europe • price category: A  
waterproof, scratchproof

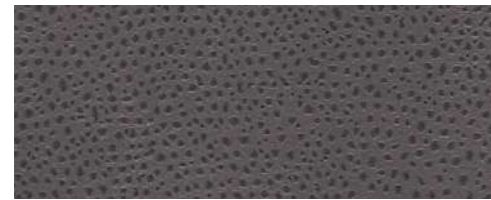

G19 • graphite

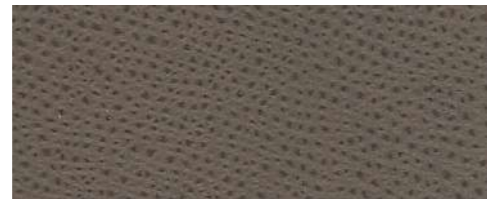

G24 • smoke

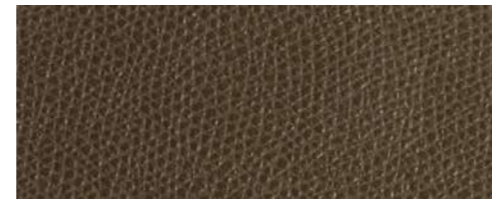

G96 • clay

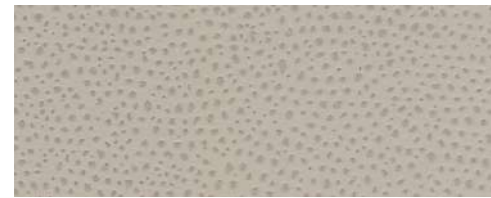

G18 • grey

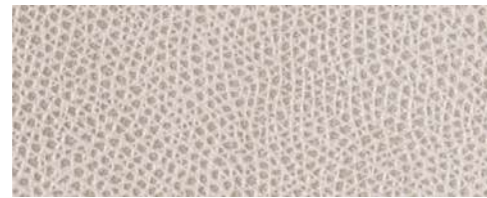

G83 • stone

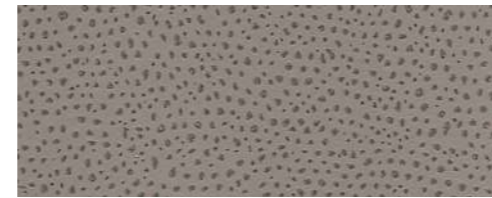

G21 • mud

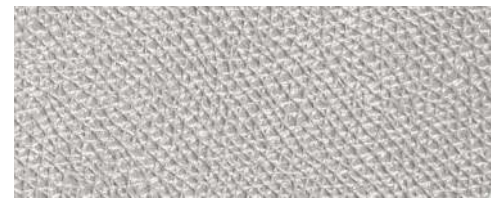

G52 • silver

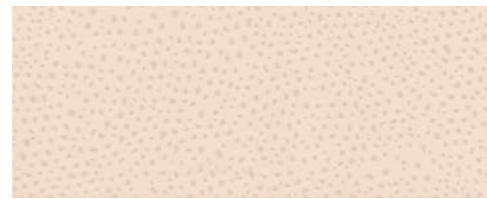

G28 • cipria



G143 • rosebud

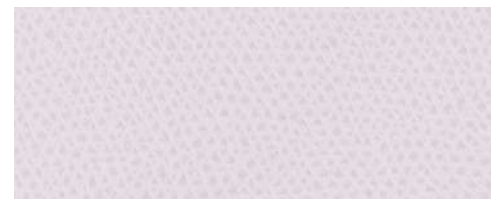

G137 • orchid ice



G61 • pearl



G123 • champagne

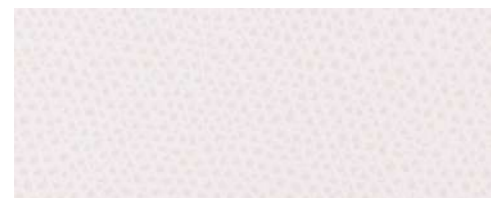

G167 • petal pink

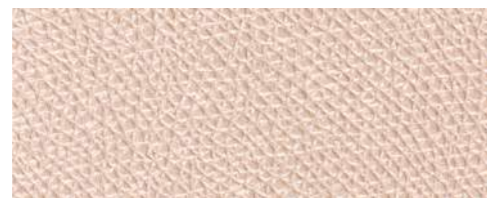

G193 • stardust

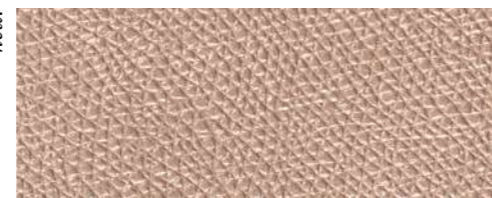

G63 • moonsand



G187 • blush pink



G91 • nude



G54 • copper



G34 • pink



G127 • flamingo



G62 • papaya



G48 • scarlet



G13 • red

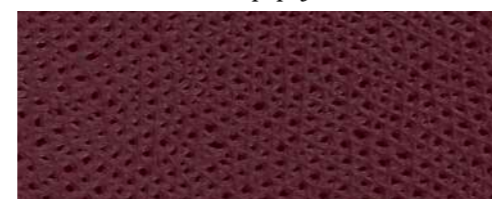

G72 • cherry

G — PRINTED CALFSKIN GOLF  
price category: A

tanned in Italy • origin: Northern Europe • price category: A  
waterproof, scratchproof

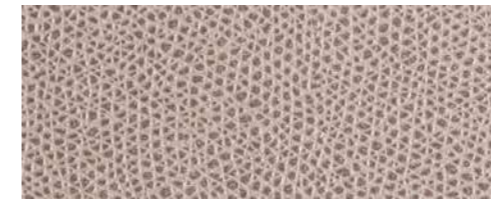

G45 • dove



G164 • peach



G67 • lava

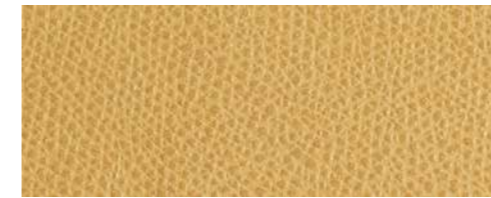

G76 • mustard

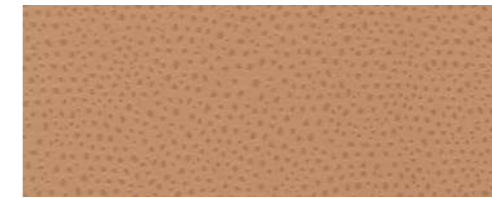

G07 • sand



G25 • moka

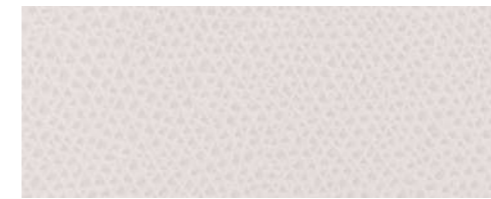

G102 • dust

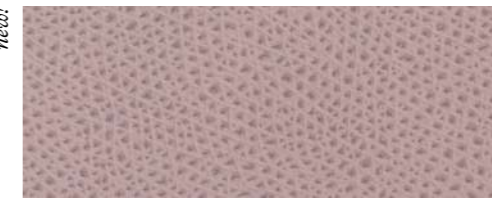

G122 • pale mauve

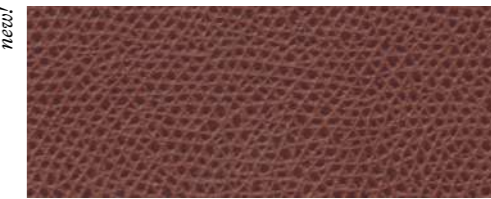

G82 • rust



G42 • cappuccino

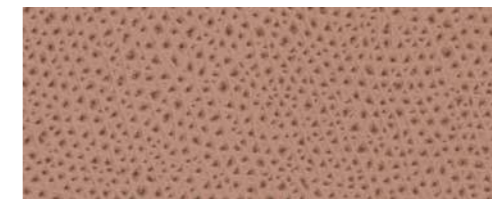

G159 • iced coffee



G93 • plum



G105 • taupe



G51 • caramel

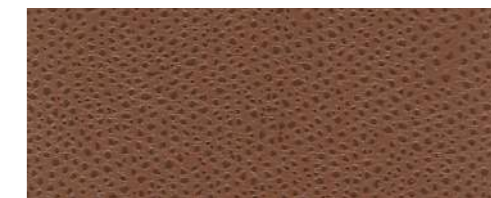

G30 • tobacco

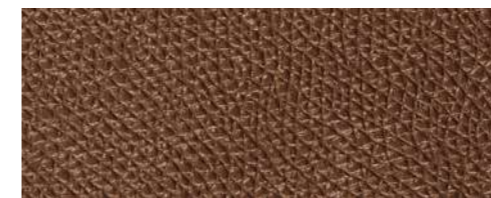

G56 • bronze

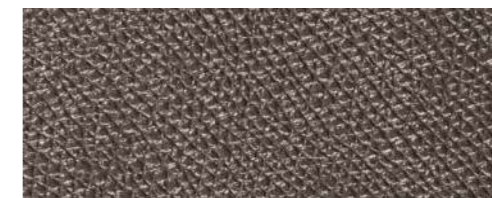

G58 • titanium

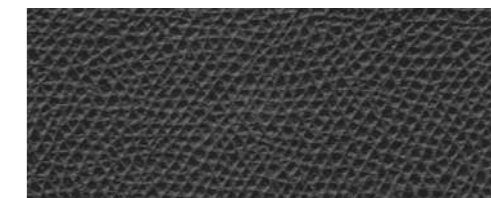

G77 • slate



G08 • siena



G36 • grape



G09 • brown



G17 • bordeaux



G16 • violet



G20 • black



F — CALFSKIN NAPPA  
price category: A

tanned in Italy • origin: Northern Europe • price category: A  
resistant to water and slightly resistant to scratches



F — CALFSKIN NAPPA  
price category: A

tanned in Italy • origin: Northern Europe • price category: A  
resistant to water and slightly resistant to scratches



## A — CALFSKIN SUEDE

tanned in Italy • origin: Northern Europe • price category: A  
scratchproof



A75 • chocolate



A24 • smoke



A37 • light grey



A08 • siena



A42 • cappuccino

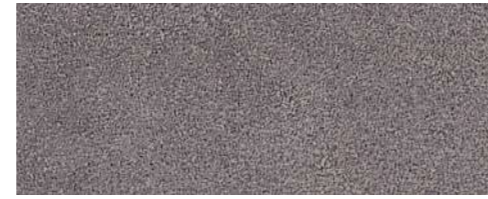

A18 • grey



A82 • rust



A06 • ivory



A05 • white



A30 • tobacco



A91 • nude



A46 • mint



A44 • terracotta



A32 • ultramarine



A17 • bordeaux



A13 • red



A12 • royal blue

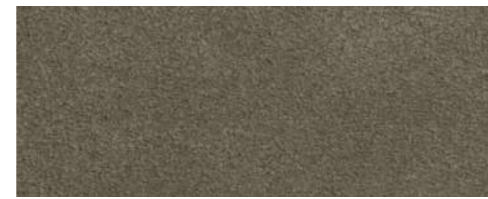

A69 • sage

## A — CALFSKIN SUEDE

tanned in Italy • origin: Northern Europe • price category: A  
scratchproof



A21 • mud



A47 • nut



A09 • brown



A76 • mustard



A80 • musk



A67 • lava



A89 • feather

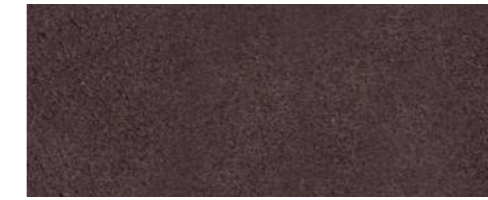

A93 • plum



A19 • graphite



A62 • papaya



A66 • sky



A31 • petrol blue



A92 • wave

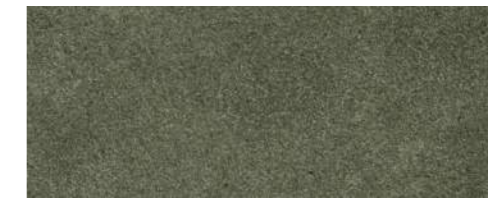

A02 • loden green



A33 • ocean

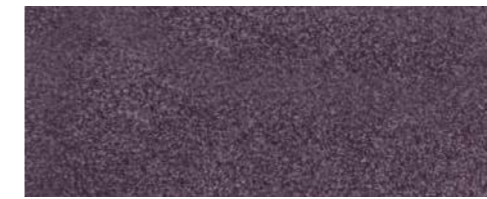

A16 • violet



A20 • black

## B — PRINTED CALFSKIN WILD BOAR

tanned in Italy • origin: Northern Europe • price category: A  
waterproof, scratchproof

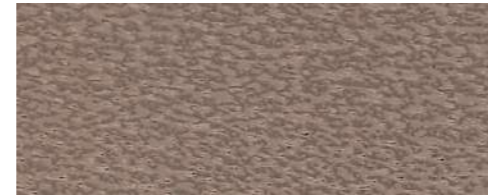
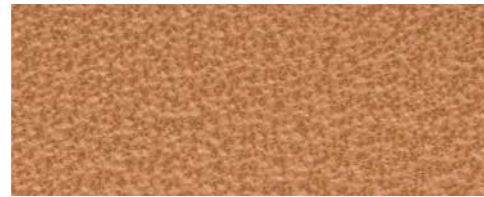
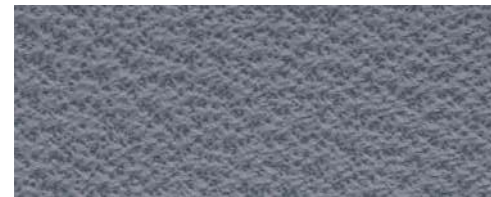
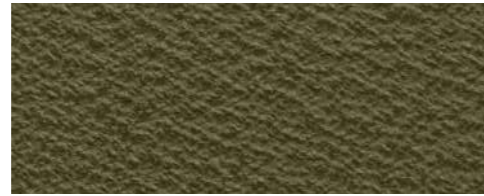
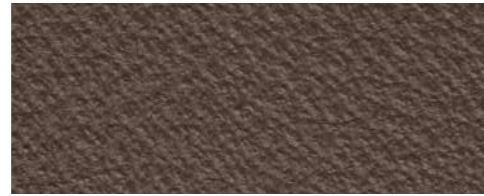
B49 • *ice*B95 • *off white*B42 • *cappuccino*B37 • *light grey*B76 • *mustard*B21 • *mud*B83 • *stone*B51 • *caramel*B67 • *lava*B41 • *storm grey*B59 • *garnet*B01 • *acid green*B17 • *bordeaux*B98 • *olive green*B38 • *mango*B33 • *ocean*B96 • *clay*B57 • *cipress*B20 • *black*B09 • *brown*B77 • *slate*

## H — PRINTED CALFSKIN DEER

tanned in Italy • origin: Northern Europe • price category: A  
water-resistant and slightly resistant to scratches

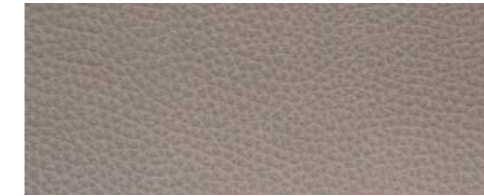
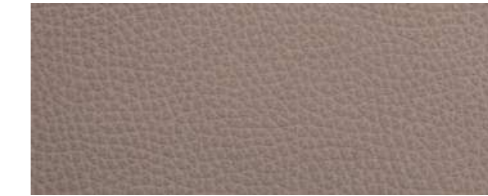
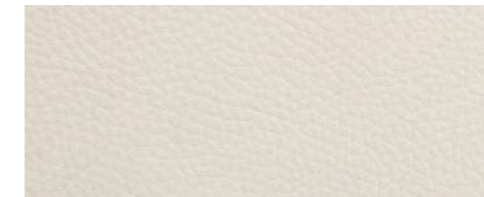
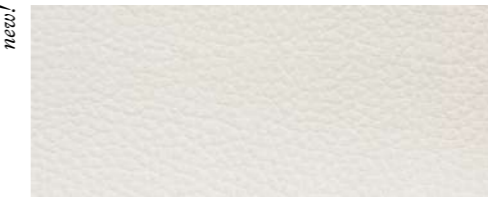
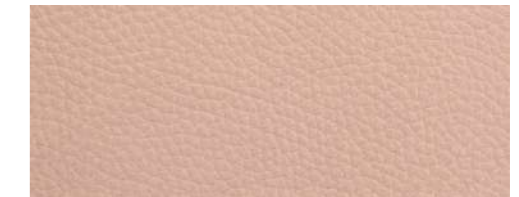
H24 • *smoke*H30 • *tobacco*H25 • *moka*H21 • *mud*H105 • *taupe*H08 • *siena*H83 • *stone*H76 • *mustard*H42 • *cappuccino*H06 • *ivory*H95 • *off white*H91 • *nude*H37 • *light grey*H113 • *guatemala*H62 • *papaya*H94 • *azure*H132 • *pumpkin*H17 • *bordeaux*H12 • *royal blue*H19 • *graphite*H67 • *lava*H20 • *black*H57 • *cipress*H93 • *plum*

## J — SHEARLING

tanned in Italy • origin: Italy • price category: SHEARLING  
not waterproof

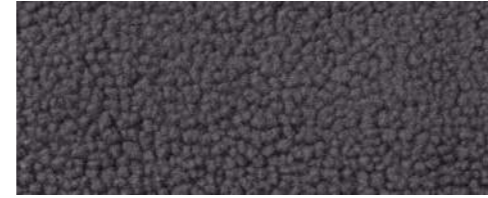
J06 • *ivory*J37 • *light grey*J19 • *graphite*J80 • *musk*J25 • *moka*J58 • *titanium*

## N — PRINTED CALFSKIN CLOUDS

tanned in Italy • origin: Northern Europe • price category: C  
not waterproof

Calf skin with black base and partial gold foil application that features a peculiar mottled effect.

N50 • *clouds*

## T — PRINTED CALFSKIN FROST

tanned in Italy • origin: Northern Europe • price category: C  
slightly waterproof

Calf skin with metal foil application. It features a pyrite-like appearance and is soft to the touch.

T51 • *frost*

## R — REAL SHAGREEN LEATHER

tanned in Italy • origin: Southeast Asia • price category: D  
only for jewellery, napkin rings and special productions

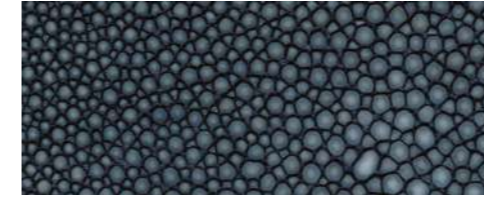
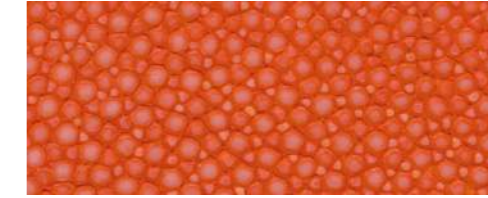
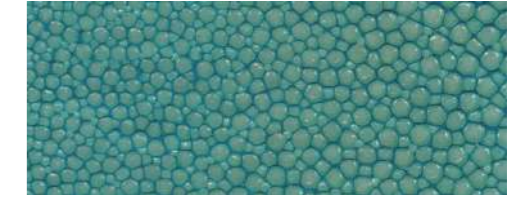
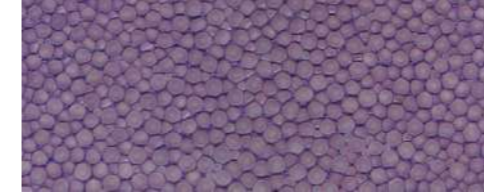
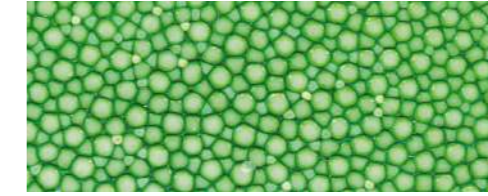
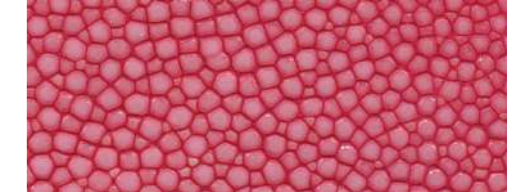
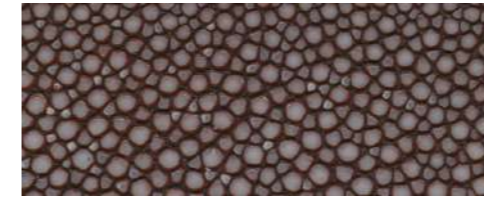
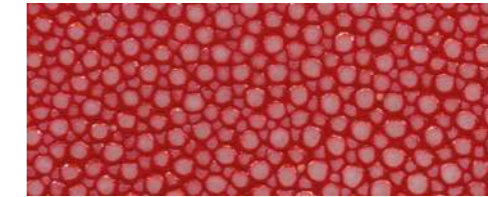
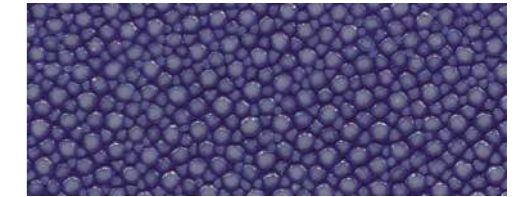
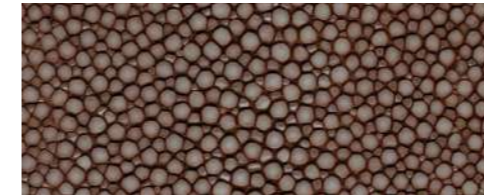
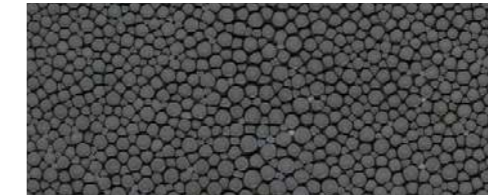
R33 • *ocean*R04 • *orange*R10 • *light blue*R29 • *lilac*R01 • *acid green*R14 • *fuchsia*R18 • *mole brown*R13 • *red*R11 • *cobalt blue*R06 • *ivory*R16 • *violet*R17 • *bordeaux*R08 • *siena*R21 • *mud*R20 • *black*

## NAPPA + SUEDE RECOMMENDED COMBINATIONS



F91 nude + A05 white



F02 loden green + A20 black



F77 slate + A66 sky

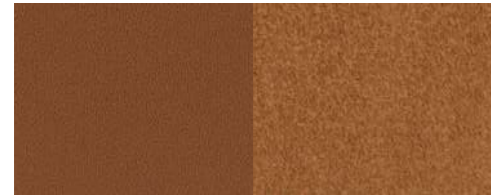

F08 siena + A30 tobacco



F24 smoke + A33 ocean

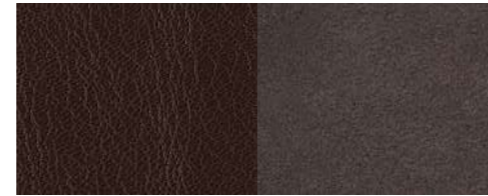

F09 brown + A67 lava



F65 antique rose + A67 lava

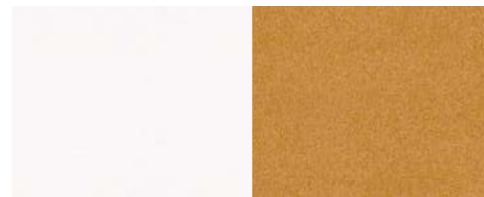

F05 white + A76 mustard

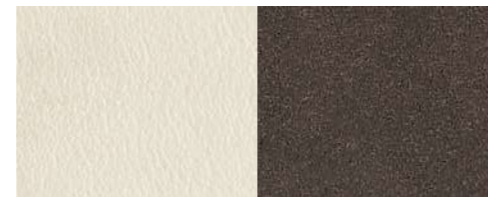

F95 off white + A21 mud



F09 brown + A37 light grey



F12 royal blue + A37 light grey



F21 mud + A06 ivory



F31 petrol blue + A75 chocolate



F82 rust + A08 siena



F65 antique rose + A17 bordeaux



F71 rock + A91 nude

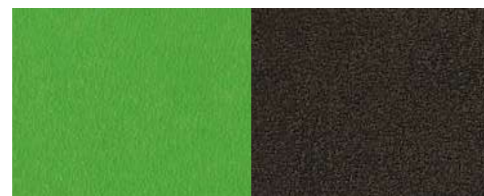

F26 apple green + A09 brown



F04 orange + A18 grey

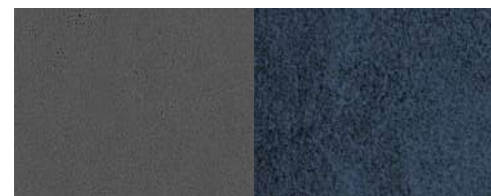

F19 graphite + A12 royal blue



F10 light blue + A80 musk



F53 pink peony + A21 mud



F68 denim + A33 ocean

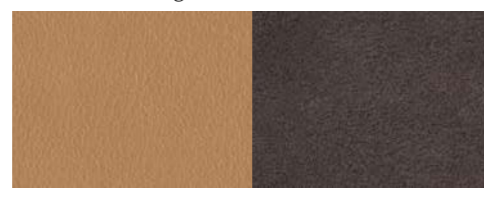

F42 cappuccino + A67 lava

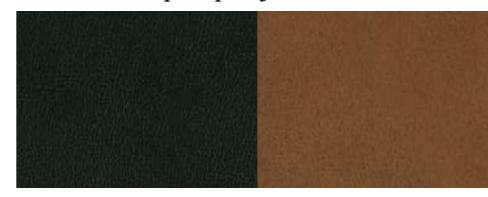

F20 black + A47 nut

## SUEDE RECOMMENDED COMBINATIONS



A05 white + A37 light grey



A91 nude + A21 mud



A06 ivory + A21 mud

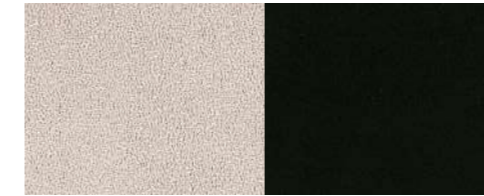

A05 white + A20 black



A75 chocolate + A17 bordeaux



A21 mud + A62 papaya



A05 white + A09 brown



A66 sky + A67 lava



A80 musk + A33 ocean



A80 musk + A09 brown

## GOLF RECOMMENDED COMBINATIONS

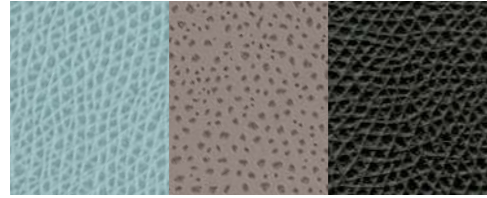

G66 sky + G21 mud + G77 slate

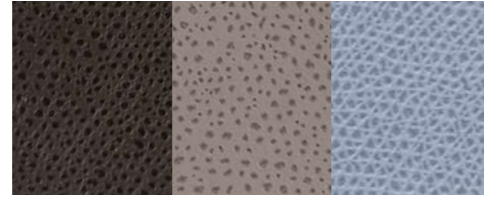

G25 moka + G21 mud + G29 lilac gray

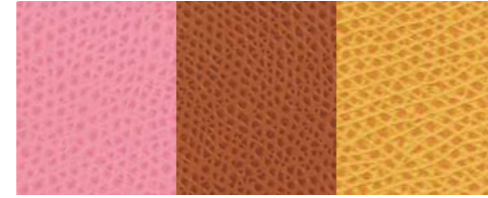

G34 pink + G08 siena + G03 yellow

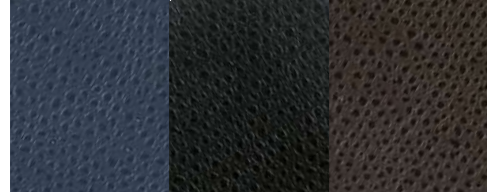

G33 ocean + G20 black + G25 moka



G28 cipria + G38 mango + G82 rust



G63 moonsand + G58 titanium + G56 bronze

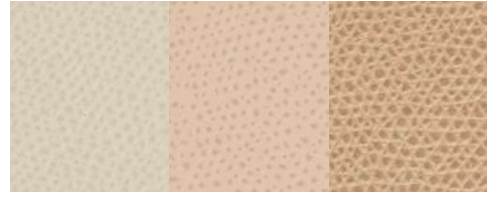

G06 ivory + G28 cipria + G42 cappuccino

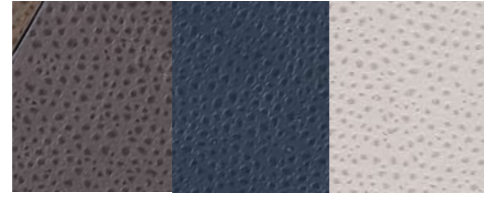

G24 smoke + G33 ocean + G37 light grey

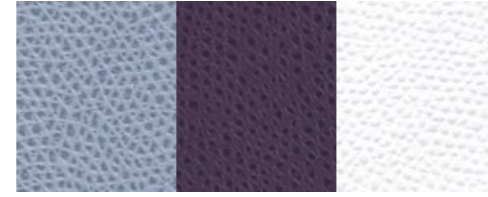

G29 lilac grey + G16 violet + G05 white

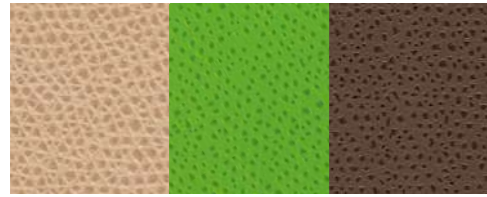

G42 cappuccino + G26 apple green + G09 brown

## NAPPA RECOMMENDED COMBINATIONS

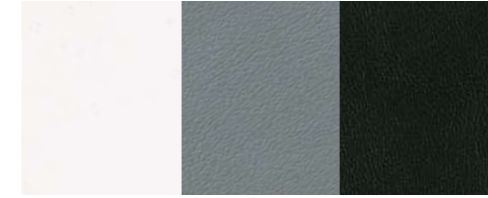

F05 white + F71 rock + F20 black



F17 bordeaux + F09 brown + F42 cappuccino

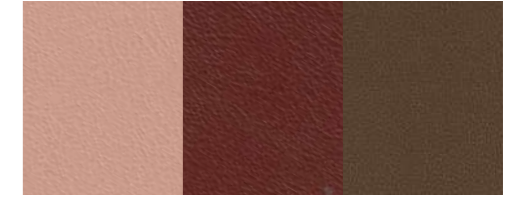

F91 nude + F17 bordeaux + F24 smoke



F42 cappuccino + F02 loden green + F95 off white



F08 siena + F20 black + F31 petrol blue



F09 brown + F08 siena + F06 ivory



F53 pink peony + F65 antique rose + F04 orange

REAL SHAGREEN RECOMMENDED COMBINATIONS

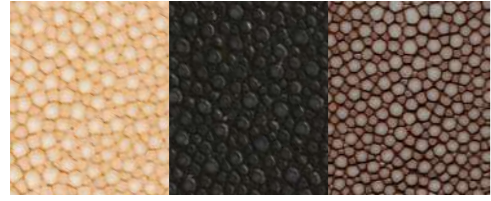

R06 *ivory* + R20 *black* + R08 *siena*

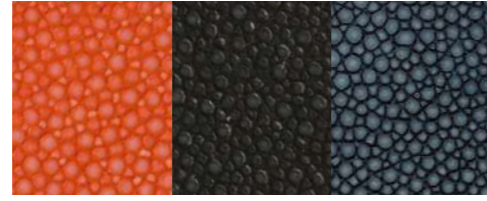

R04 *orange* + R20 *black* + R33 *ocean*



R14 *fuchsia* + R17 *bordeaux* + R08 *siena*

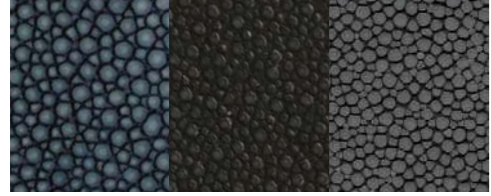

R33 *ocean* + R20 *black* + R21 *mud*

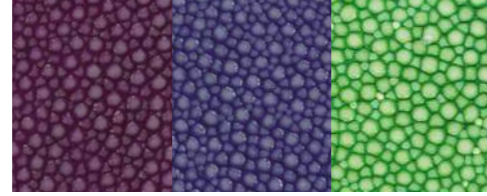

R16 *violet* + R11 *cobalt blue* + R01 *acid green*



R20 *black* + R08 *siena* + R10 *light blue*

OTHER  
FINISHES

WOOD FINISHES

you can choose among 3 different finishes or ask us for other option



WENGE



WALNUT



NATURAL



DARK WALNUT

LACQUERED WOOD FINISHES

you can choose among 7 different finishes or ask us for other option

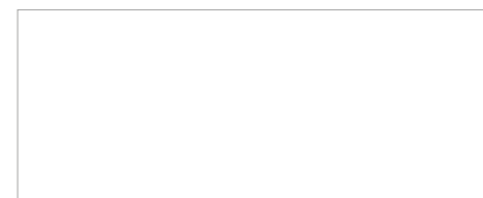

WHITE

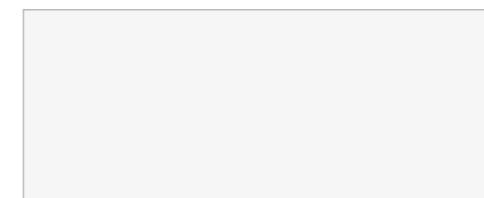

OFF WHITE

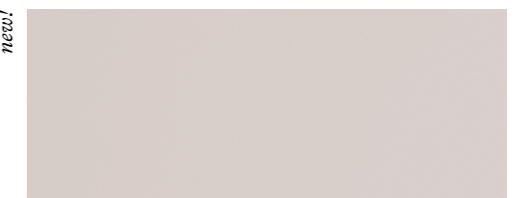

LIGHT GREY

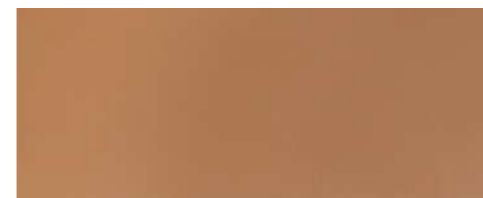

CAPPUCCINO



SAGE



MUD

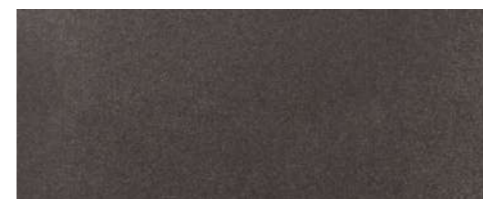

BRONZE

new!

new!



METAL FINISHES

Choose from 3 standard finishes or inquire about custom options.



POLISHED CHROME

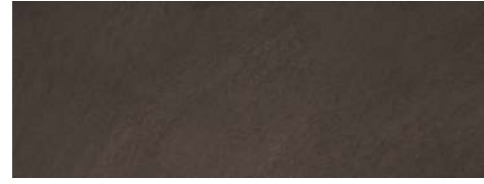

BRUSHED BRONZE



BRUSHED BRASS

MARBLE FINISHES

Choose from 5 standard finishes or inquire about custom options.



TRAVERTINO



TRAVERTINO WALNUT



TRAVERTINO SILVER



TRAVERTINO YELLOW



TRAVERTINO RED

*creative direction*  
Stéphane Parmentier

*graphic design*  
Giobagnara studio

*photography*  
Cartacarbone  
Giobagnara studio  
Luxproductions

*special thanks to*  
Agé Modernariato  
Hotel Palazzo Grillo  
Michael Haentjes  
Andrea Schito  
Tato Italia  
Via Garibaldi 12 Lifestylestore

# GIOBAGNARA

[www.giobagnara.com](http://www.giobagnara.com)  
[info@giobagnara.com](mailto:info@giobagnara.com)

*Follow us on:*

 @giobagnara  
#giobagnara

 GIOBAGNARA

## *manufacture / headquarters*

via Luciano Manara, 2  
16153 Genova — Italy  
ph. +39 010 2518989

## *showroom*

via Garibaldi, 12  
16124 Genova — Italy  
ph. +39 010 25 30 365

## *flagship stores*

Calle delle Ostreghe, 2456 – 2459  
30124 Venice — Italy  
ph. +39 041 5231148

Piazza San Marco, 60 – 61  
30124 Venice — Italy  
ph. +39 041 9348009

Piazza San Marco, 289 – 305  
30124 Venice — Italy  
ph. +39 041 3073962

Piazza San Marco, 313 – 314  
30124 Venice — Italy  
ph. +39 041 9349548

Westerweg, 12  
25999 Kampen, Sylt — Germany  
ph. +49 (0)4651 9677530

## *shop in shop*

KaDeWe  
Tauentzienstrasse 21 - 24  
10789 Berlin — Germany  
5th floor, corner S.A5.01

## *press contact*

LFO\_ Liza Fitoussi Office  
[contact@agencelfo.com](mailto:contact@agencelfo.com)  
+33 (0)148 781528

All designs are registered.